

# MINI ELECTROMAGNETIC METER



## FEATURES

- Compact design suitable for liquids from 10 $\mu$ S/cm
- Compact and low cost
- Easy installation and less maintenance
- Minimum flow rate can be as low as 5L/h
- Optional temperature sensor integrated is available
- Bi-directional measurement with independent total counters; Empty pipe detection is integrated
- PEEK liner and optional EPDM seals are available for hygiene measurement
- No movable parts, no mechanical wear and tear
- Threaded connection for easy installation
- Easy operation and various outputs are available
- DC 24V powered with or without display

## TECHNICAL DATA

<b>Nominal Diameter</b>	DN3~DN20
<b>Electrode Material</b>	316L, Hb, Hc, Ti
<b>Lining Material</b>	PEEK
<b>Dielectric Conductivity</b>	$\geq 10\mu\text{S/cm}$ , softened water $20\mu\text{S/cm}$
<b>Accuracy Level</b>	$\pm 0.5\%R \sim \pm 1.0\%R$
<b>Flow Range</b>	0.3m/s ~ 10m/s
<b>Ambient Temperature</b>	-10°C ~ 60°C
<b>Measuring Temperature</b>	-20°C ~ 100°C
<b>Nominal Pressure</b>	0.6MPa~1.6MPa
<b>Protection Level</b>	IP65、IP67(Blind)
<b>Installation Form</b>	Compact
<b>Shell Material</b>	Aluminum with epoxy
<b>Connection</b>	Threaded, G1/2, G3/4, NPT 1/2 or others, SS304/SS316
<b>Output Signal</b>	frequency/pulse, MODBUS-485 communication
<b>Operating Voltage</b>	24VDC $\pm 20\%$ (19.2V-28.8V)
<b>Current Consumption</b>	< 150mA
<b>Dimension(HxWxD)</b>	150*100*70 (mm)

## TECHNICAL DRAWINGS

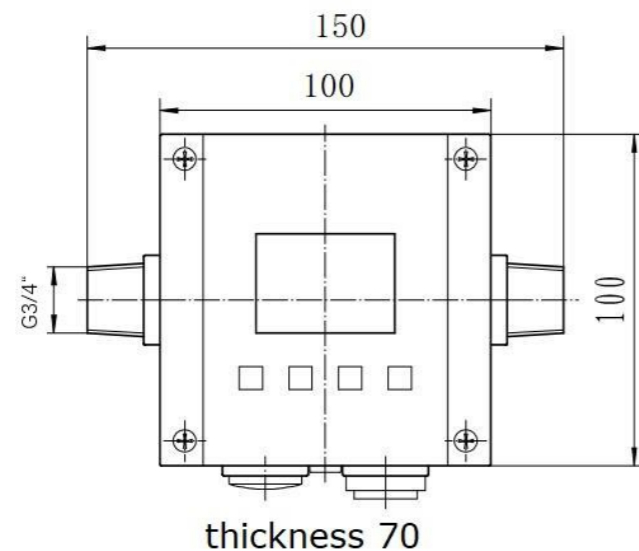

Tlf: 67 150 250 Faks: 67 150 251

Mail: [post@instrumentteam.no](mailto:post@instrumentteam.no)

Web: [www.instrumentteam.no](http://www.instrumentteam.no)