

Lumiglas Tubular Sight glass/Flow Indicator flanged at both ends to DIN 2642 for fitting into pipelines

- **Application:**
For visual control of state of fluid and flow in pipelines
- **Connecting flanges:**
Flanges to DIN 2642 (mating sizes PN 10)
- **Length over flange:**
DIN 3202 F1
- **Operating conditions:**
Operating pressure: up to 6 bar, depending on wall thickness
(higher ratings on request)
Operating temperature: up to 220°C

Materials of components

referred to in adjoining exploded view:

Item	Part	Material
1	Connecting flange	Stainless steel 1.4571 or other
2	Glass cylinder	Borosilicate glass (DURAN)
3	Ring seals	Silicon rubber or other
4	Spacer bars	Stainless steel 1.4301 or other
5	Securing bolts	A 2 or other (with spring washer)
6	Shatter protection	Plastic pipe or protective grid made of stainless steel

Installation:

The flow indicator is bolted, using suitable gaskets, directly between the mating flanges of the pipeline.
The flow indicator should be fitted so that no stresses (tensile, compression or torsional) are caused on tightening up.

Special versions:

- with stainless steel or protective plexiglass outer shell
- ANSI flanges
- customised length

Optional:

- available with splinter protection

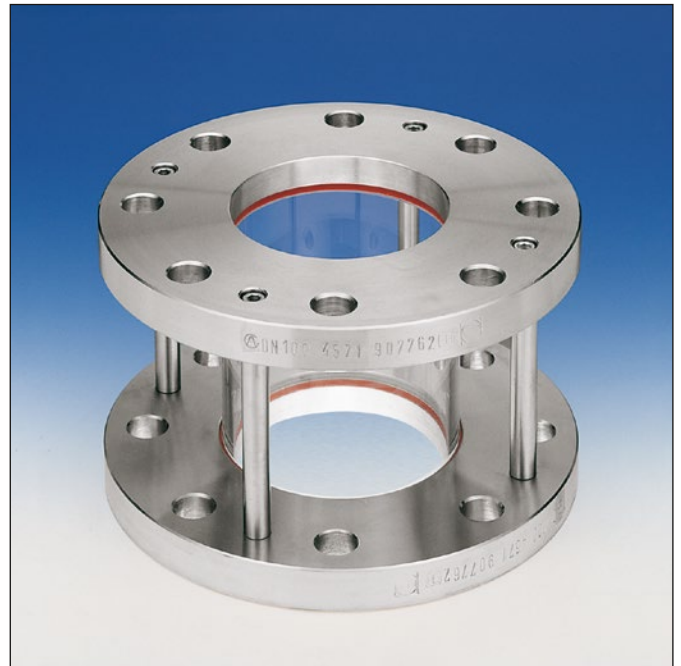

Lumiglas tubular sight glass/flow indicator

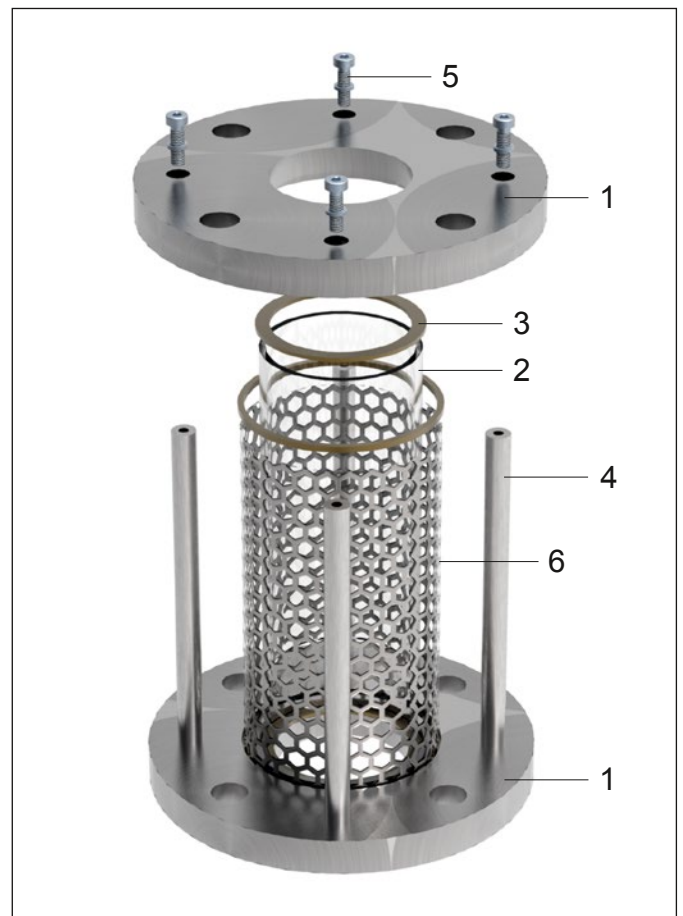

Exploded view of a
Lumiglas tubular sight glass/flow indicator
with protective grid

• Dimensions for Lumiglas tubular sight glass/flow indicator:

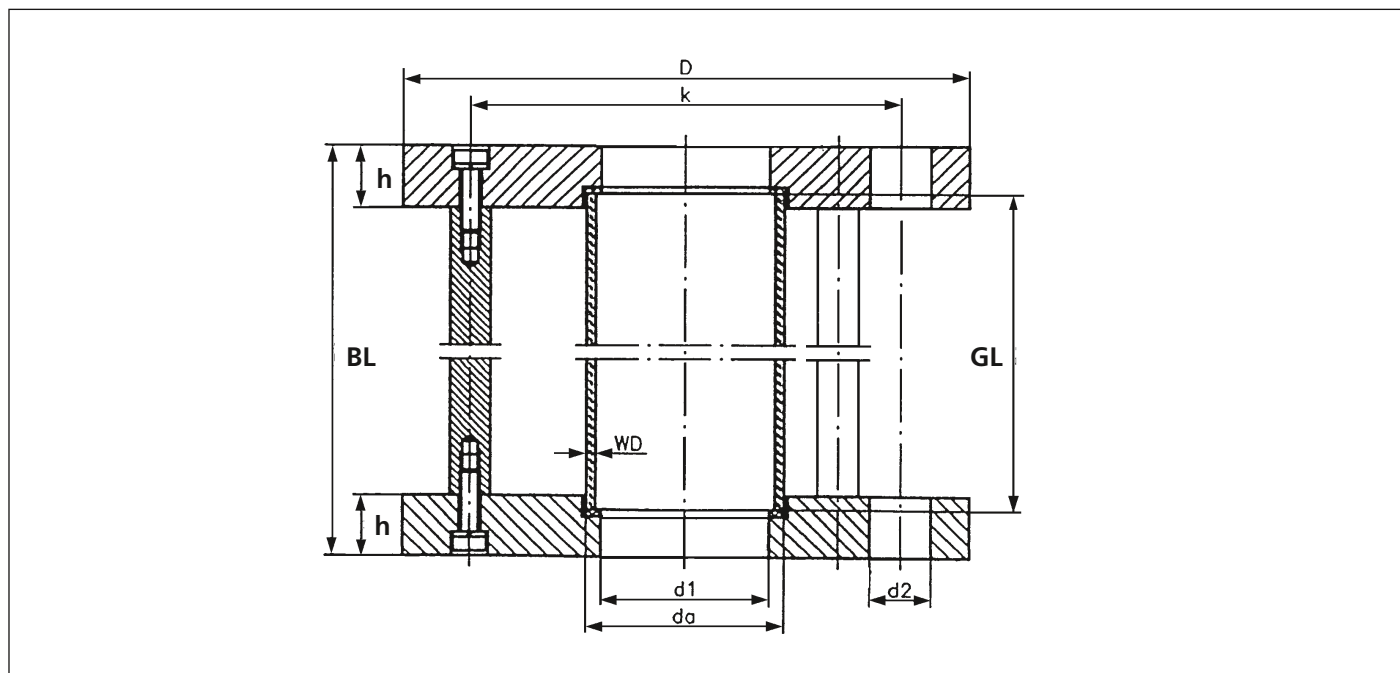

Fitting		Part no.	Max. pressure bar	Flanges			Conn. bolt hole + securing bolts			Glass cylinder		
DN	BL			D	d1	h	k	No.	d2	da	WD	GL
10	130	0201.081.00	6	90	10	16	60	4	14	15	1.8	106
15	130	0201.082.00	6	95	15	16	65	4	14	18	1.8	106
20	150	0201.083.00	6	105	20	16	75	4	14	24	1.8	126
25	160	0201.084.00	6	115	25	18	85	4	14	30	1.4	132
32	180	0201.085.00	6	140	32	18	100	4	18	38	2.0	152
40	200	0201.086.00	6	150	40	18	110	4	18	48	2.3	172
50	230	0201.087.00	5.6	165	50	18	125	4	18	58	2.5	202
65	290	0201.088.00	5.6	185	65	18	145	4	18	75	3.2	262
80	310	0201.089.00	6	200	80	20	160	8	18	95	5.0	278
100	350	0201.090.00	5.3	220	100	20	180	8	18	115	5.0	318
125	400	0201.091.00	6	250	125	20	210	8	18	140	7.0	368
150	480	0201.092.00	5.0	285	150	20	240	8	22	170	7.0	448
200	600	0201.093.00	4.9	340	200	22	295	8	22	225	9.0	564

• Ordering information:

e. g. Lumiglas tubular sight glass/flow indicator DN 100, material 1.4571, borosilicate glass, 5.3 bar operating pressure, length over flanges 350