

Lumistar vehicle luminaires for special vehicles operating in potentially explosive environments

Luminaires for vehicles used in Ex category environments must not only meet all requirements on driving safety, but also need to comply with the Ex directives specified by ATEX. At the same time, they are expected to be reasonably priced. These complex demands are met by Lumistar Ex vehicle luminaires which are approved for use in potentially explosive environments: Gas: zone 1 and 2; Dust: zone 21 and 22.

1. Front lamp or reversing light

Lumistar Ex vehicle luminaire type USL 07-Ex

• **Rated voltage:** 24 V AC/DC

• **Certification:** EC Type-Examination Certificate
BVS 08 ATEX E 136

 II 2G Ex de IIC 120°C Gb
II 2D Ex tb IIIC T120°C Db

• **Dimensions:**

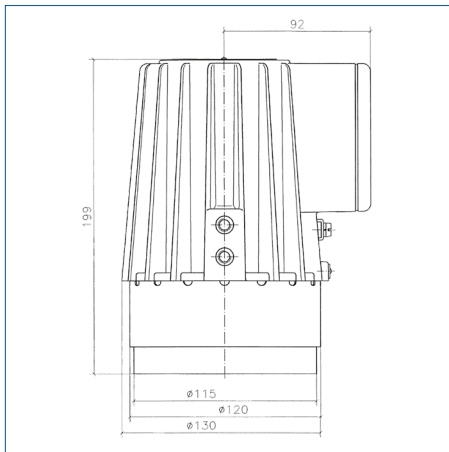

2. Flashing light

Lumistar Ex flashing luminaire type USL 45A-Ex

• **Rated voltage:** 12 V, 24 V AC/DC, with 5 W halogen lamp

• **Connecting lead:** 5 m H07RN-F, 3x1.0 mm² (included)

• **Flasher relay:** required externally (installed in vehicle!)

• **Certification:** EC Type-Examination Certificate
BVS 08 ATEX E 134

 II 2G Ex d IIC 120°C Gb
II 2D Ex tb IIIC T120°C Db

• **Dimensions:**

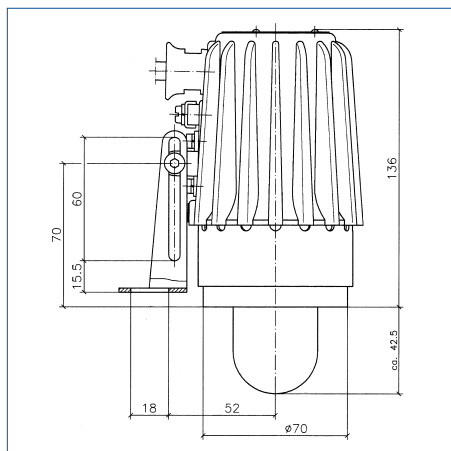

• Application:

Primarily used on special vehicles operating in the industrial sector, such as fork lifters, stacker trucks, tank trucks, etc., that are mainly driven in explosion hazardous environments.

• Variants of Lumiglas VISULEX Ex vehicle luminaires:

1. Driving lights – front headlight or reversing light
2. Flasher – direction indicator (front)
3. Combined brake light, rear lamp and rear flasher

 0158



1. Lumistar Ex vehicle luminaire type USL 07-Ex with terminal box

 0158



2. Lumistar Ex flashing luminaire type USL 45A-Ex with accessory: stainless steel mesh guard with hinged bracket

3. Combined brake light, rear lamp and direction indicator flasher

Lumistar Ex combination luminaire type USL 46-Ex

- **Rated voltage:** 12 V, 24 V DC with 7 W LED illuminant

- **Certification:** EC Type-Examination Certificate
BVS 08 ATEX E 135

 II 2G Ex de IIC 120°C Gb
II 2D Ex tb IIIC T120°C Db

- **Mounting:** Using either a hinged bracket or a (customised) three-point fastening

- **Dimensions:**

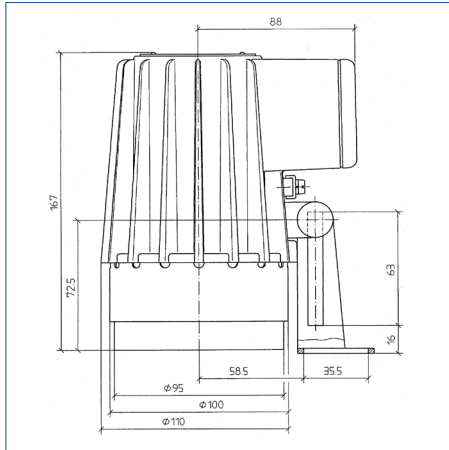

CE 0158

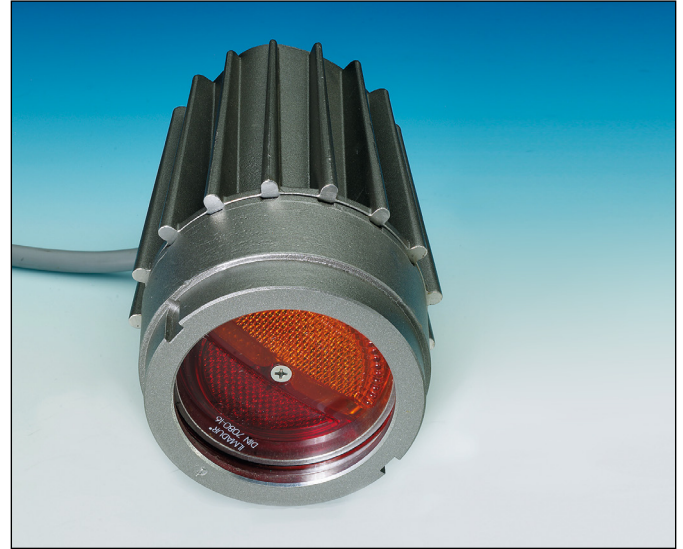

Lumistar Ex vehicle luminaire,
type USL 46-Ex with terminal box

4. Criteria for all Lumistar Ex vehicle luminaires:

- **General technical data:**

- Protection: IP65 and IP67 acc. to DIN EN 60529
- Ambient temperature range: -20°C to +40°C

- **Explosion protection:**

These lamps meet the essential health and safety regulations by complying with the directives for

a) Gas

EN 60079-0:2012 General Requirements
EN 60079-1:2007 Flame-proof Enclosures
EN 60079-7:2007 Increased Safety
(relates to terminal box)

Explosion group: IIC (covers IIA and IIB)
Temperature class: 120°C

b) Dust

EN 60079-0:2009 General Requirements
EN 60079-31:2009 Protection by Enclosures
Explosion group: IIIC (covers IIIA und IIIB)
Temperature class: T120°C

- **Components, design and materials:**

- Body of luminaire: corrosion-resistant cast aluminium alloy, GK-Al Si 10 Mg
- Lens: unit consisting of aluminium ring and glass with O-ring seal
- USL 45 A-Ex:
Screw-on glass lens with calotte: Unit consisting of aluminium ring with polycarbonate (Makrolon) calotte.