

Lumiglas Sight Glass Disc, Circular, With Central Hole 10.5 mm \varnothing

3755.164 c

Dimension D x s (mm)	Viewing Diameter d_1 (mm)	Nominal Pressure (bar)
Other dimensions on request		
Soda lime glass, material acc. to DIN 8902 – up to 150°C		
63 x 10	48	6
80 x 12	65	6
94 x 12 ¹⁾	80 ¹⁾	6
100 x 15	80	6
113 x 15 ¹⁾	100 ¹⁾	6
125 x 15	100	6
141 x 15 ¹⁾	125 ¹⁾	6
150 x 15	125	5
166 x 15 ¹⁾	150 ¹⁾	4
175 x 15	150	4
200 x 15	175	4
225 x 15	205	2
250 x 15	225	2
Borosilicate glass, material acc. to DIN 7080 – up to 280°C		
63 x 10	48	6
80 x 12	65	6
94 x 11 ¹⁾	80 ¹⁾	6
100 x 15	80	6
113 x 15 ¹⁾	100 ¹⁾	6
125 x 15	100	6
141 x 15 ¹⁾	125 ¹⁾	6
150 x 19	125	6
166 x 15 ¹⁾	150 ¹⁾	6
175 x 19	150	6
200 x 19	175	4
225 x 15	205	2
250 x 25	225	4

¹⁾ For screwed sight glass fittings, material acc. to DIN 11851

- For pressure duties, no lower temperature limit
- Toughened Sodalime or Borosilicate glass
- Ground and polished
- Optional extras possible, e. g. coating!

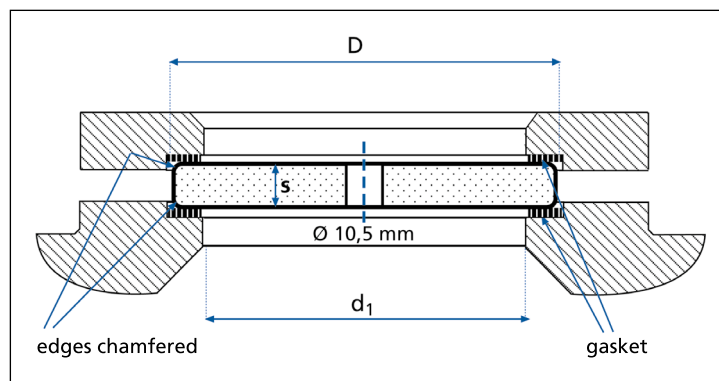

All dimensions in mm unless stated otherwise. Subject to change without prior notice. 11.15

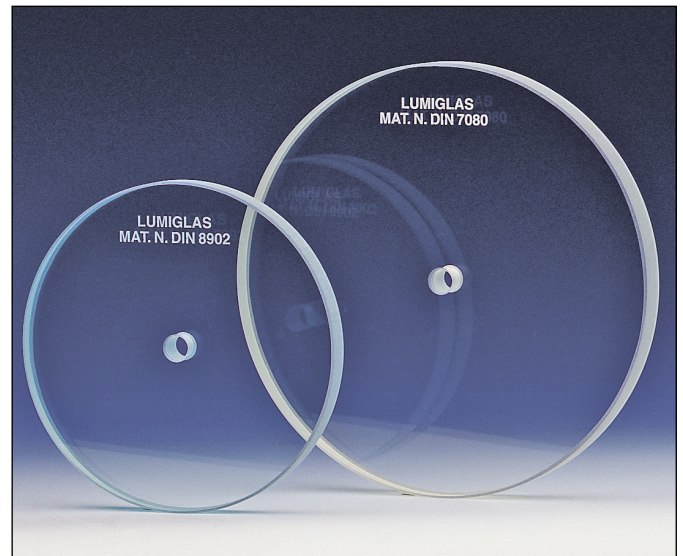

• Safety precautions when using sight glass discs:

1. Whenever a sight glass assembly has been taken apart it is urgently recommended in accordance with DIN 7080/DIN 8902 that the glass disc and gaskets are replaced by new ones. That is particularly important in the case of pressure vessels and/or aggressive media.

The following extract from DIN 7080/DIN 8902 text is verbatim:

'Sight glass discs may only be installed by personnel who have been informed fully about the following requirements:

- care in handling sight glass discs
 - cleaning of recesses, sight glass discs, gaskets and other parts i. e. removal of foreign bodies (e. g. swarf), prior to installation/reassembly
 - even tightening of retaining bolts
- Sight glass discs that have been removed after operating use must not be re used.'

2. Planned maintenance:

Sight glass discs should be included in routine maintenance and periodically checked visually or using ultrasound wall thickness measuring means. In the event of damage, a glass disc must be promptly exchanged, with the plant first having been brought to a standstill. The service life of a sight glass, relative to the particular vessel in which it is mounted, should be established by regular and careful visual check of its condition.

Caution: Completely demineralised water may dissolve glass – especially intensive periodical inspection required!

3. Breakage of a sight glass:

In spite of careful installation and recommended use, sight glass discs can, on rare occasions, suffer breakage through external influences. In order to prevent the entry of glass particles into products of a critical nature, e. g. foodstuffs, appropriate safety precautions should be taken by the plant manufacturer or user.