

## Lumiglas Signalling Device M55-BD-Ex



II 2G Ex db IIC T6 Gb  
II 2D Ex tb IIIC T80°C Db

### The smart motion detector/twilight switch:

- The smart motion detector/twilight switch: The M55-BD-Ex automatically switches the light or other users in potentially explosive (Ex) indoor or outdoor areas on and off again.
- Although it has been designed for explosion-protected environments, it can also be used in non-hazardous areas.
- The motion detector is equipped with radar sensor technology and the twilight switch is operated by an optical sensor.
- Implementing the M55-BD-Ex ensures energy-saving operation.
- Numerous applications are feasible thanks to the wide variety of sensor setting options. For instance, the motion detector and twilight switch can be used either separately or in combination.
- Typical applications are:
  - Alarm when entering hazardous areas
  - Switching lights on and off depending on brightness and/or motion
  - Useful as a signal generator for acoustic and optical devices (e.g. horns, warning lamps)
  - Leakage detector on or below container and/or installations (responds to drops)
- Potential-free contact means that the M55-BD-Ex can also be used to generate signals for other control units.
- Stainless steel body: 1.4404

- **Protection class:** IP 65 and IP 67

### • Operating conditions:

Under no circumstances should the movement/brightness detector M55-BD-Ex be used to replace the cover flange or the complete sight glass fitting nor on its own as a closure for a vessel port.

- **For use in ambient temperatures:** -20°C to +40°C

- **EC type examination certificate:** BVS 15 ATEX E 057 X



II 2G Ex db IIC T6 Gb  
II 2D Ex tb IIIC T80°C Db

- **Operating voltage:** 230 V AC or 24 V AC/DC

### • Special conditions to ensure safe use:

- Minimum length of connecting cable: at least 1 meter
- The connecting cable should be installed to ensure that no electrostatic hazard can occur

- **Convenient electrical connection with integrated connecting cable**

### • Mounting options:

- Attachment using the hinged bracket included in the scope of supply, stainless steel 1.4301
- Alternative securing options on request

CE 0158

3755.359 c



Lumiglas signalling device M55-BD-Ex

# Lumiglas

• **Dimensions and technical data for Lumiglas signalling device M55-BD-Ex:**

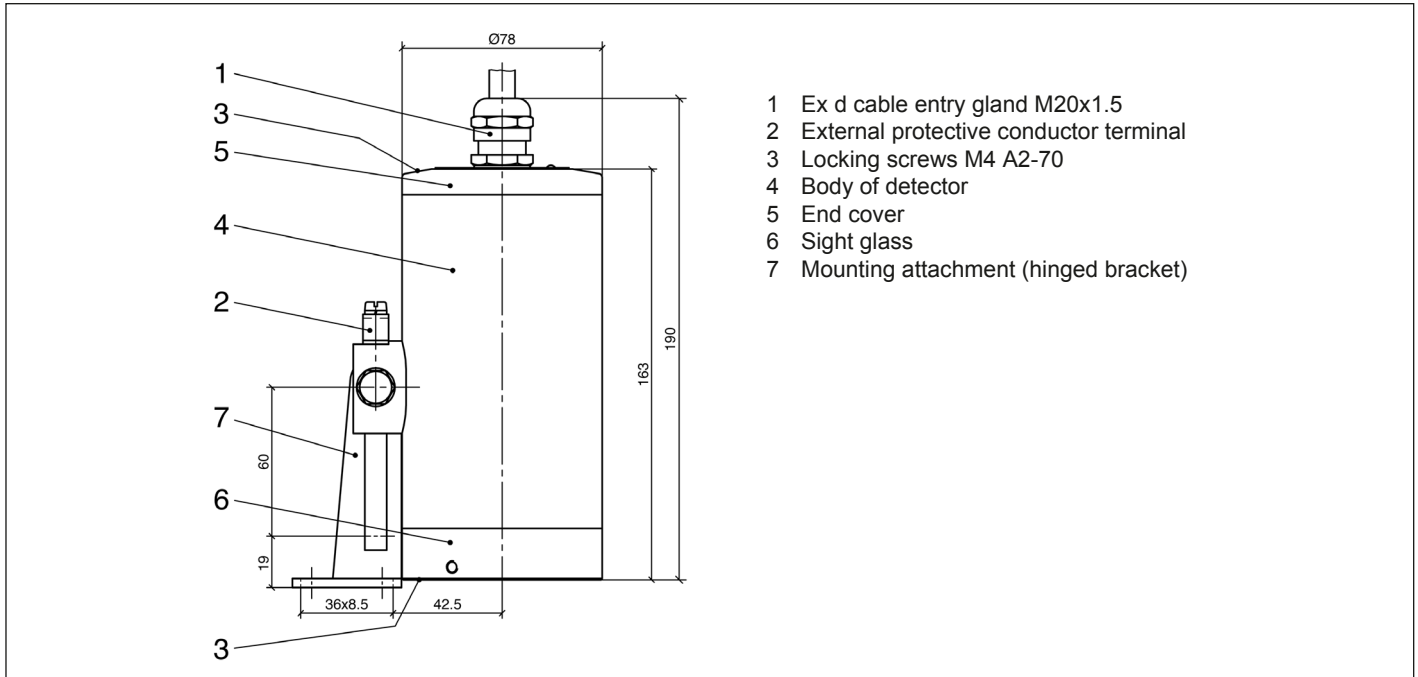

• **Parts, description and materials:**

- Body: stainless steel 1.4404
- Hinged bracket for attachment: stainless steel 1.4301
- Aperture for the sensors: borosilicate glass

- Weight incl. hinged bracket and 3 m connecting cable 5 x 1 mm<sup>2</sup>: 3.9 kg

• **Electrical connection:**

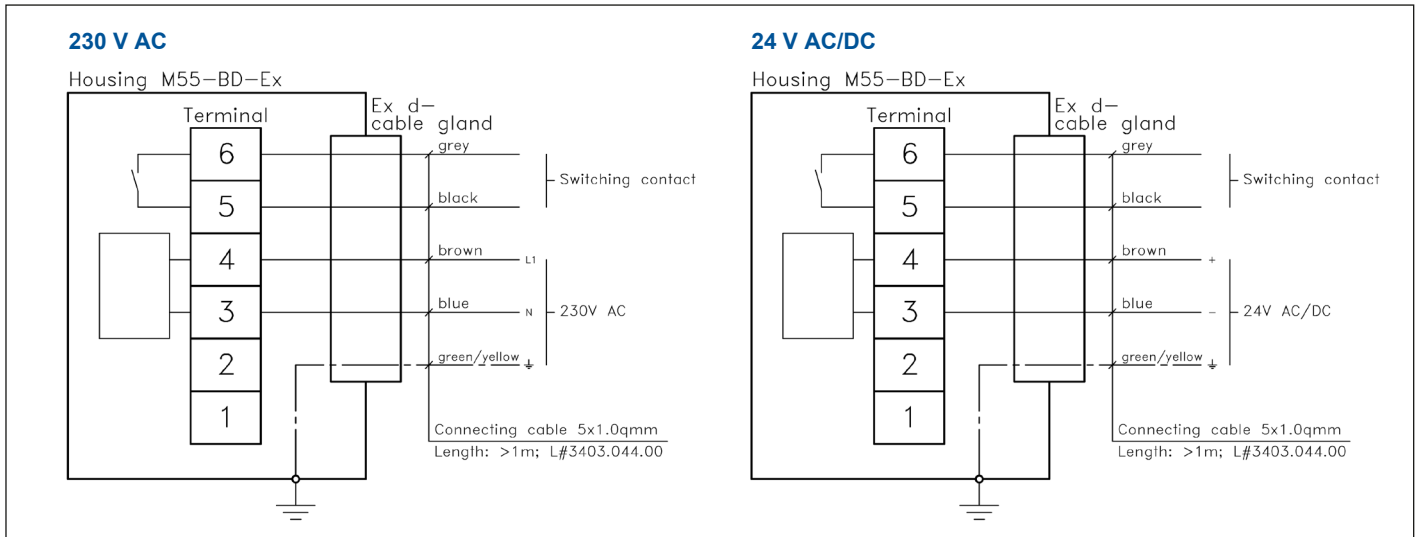

- Rated power of electronics: 5 W
- The potential-free contact (relay) switches up to 250 V AC / 5 A / 1250 VA
- Coverage of radar sensor: 72° horizontal and 60° vertical
- Radar sensor range: approx. 10 m
- Sensitivity of radar sensor is adjustable via switch
- Signalling time of switching contact is adjustable via potentiometer (between 5 sec. and 3 min. – other times possible)
- Twilight sensor range adjustable via potentiometer (1-1400 Lux)

Item	Type	Voltage V	Part no.
1	M55-BD-Ex	230 V AC	1702.702.00
2	M55-BD-Ex	24 V AC/DC	1702.701.00

- **Accessories:** Ex-e terminal box 8118, part no. 2507.020.00  
Protective hood for outdoor applications, part no. 1988.026.00

- **Order data:** M55-BD-Ex, 230 V AC (part no. 1702.702.00), 5 m connecting cable, protective hood (part no. 1988.026.00)

All dimensions in mm unless stated otherwise. Picture credits: ©F.H. Papenmeier GmbH & Co. KG. Subject to change without prior notice. 03.20