

## VISULEX Camera K15-P-D/K15-N-D, Stainless Steel

### • Camera with fixed lens K15-P-D/K15-N-D:

The lens of this basic standard camera is focused during the installation process on the object to be monitored (external facilities/outdoor areas or technical process elements such as e. g. boilers or agitators).

### • Structure and application:

- Stainless steel housing with built-in colour CCD camera, 1/3" CCD sensor, 1 lux photosensitivity; including electronics and stainless steel hinge as a mounting bracket
- Type of protection: IP 65
- Operating conditions: Ambient temperature +5° C to +40° C

### • Angle of view: 28°-120°

Minimum lens-to-object distance: 80 mm  
(see order info on reverse)

### • Electrical connection:

- Via an external power supply unit (included in the scope of supply), primary 100-240 V 50/60 Hz, secondary 12 V DC
- Voltage: 12 V DC (via power supply unit)
- Power rating: up to 20 W

### • Installation:

- The camera is attached to the cover flange of a circular sight glass (DIN 23120 or equivalent) using the stainless steel bracket provided (hinge 1.4301). The method used is the same as for the internationally approved Lumiglas luminaires. If there is insufficient natural light in the vessel, an appropriately dimensioned Lumiglas luminaire can be installed additionally.
- A separate arrangement of lighting glass and camera glass is a further option to be considered. This depends not only on the process and the reactor size, but also on the surface of the vessel, the medium in question, and the angle of incidence.
- Consistently uniform illumination is essential.

CE

3755.425 c



VISULEX camera K15-P-D with fixed lens

### • Control wire:

- Coaxial cable 75 Ω
- Length: up to approx. 100 m  
(between camera and display monitor)

### • Power supply line:

Power supply to camera: 3-core cable, length max. 50 m

### • Weight: 0.8 kg excluding control wire

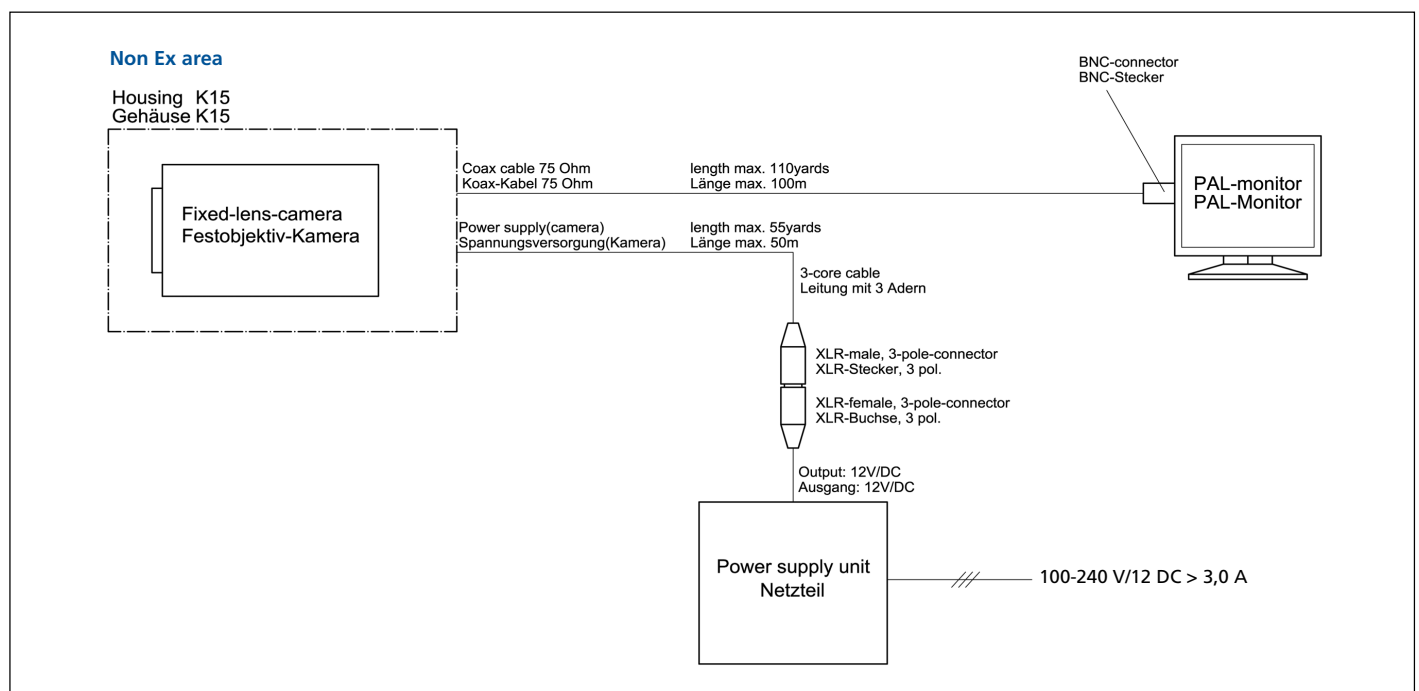

• Dimensions and technical data for VISULEX Camera K15-P-D/K15-N-D:

Camera	K15-P-D (PAL)	K15-N-D (NTSC)
Camera standard	CCIR (Europe)	EIA (USA)
Image sensor	1/3"-CCD	1/3"-CCD
Pixels	approx. 440,000	approx. 380,000
Light sensitivity	1 lux	1 lux
Resolution	480 lines (horizontal)	480 lines (horizontal)
Electronic shutter speeds	automatic, 1/1-1/10,000	automatic, 1/1-1/10,000
S/N ratio	>48 dB	>48 dB
Aperture control	automatic	automatic
Colour system	PAL 752 x 582	NTSC 768 x 492

Power supply unit	primary	secondary
Voltage and power consumption	100-240 V AC 50/60 Hz 1,5 A	12 V DC > 3,0 A
Dimensions mm (H x W x D)	40 x 150 x 70	40 x 150 x 70

Note: Power supply unit for 24 V DC/12 V DC on request.

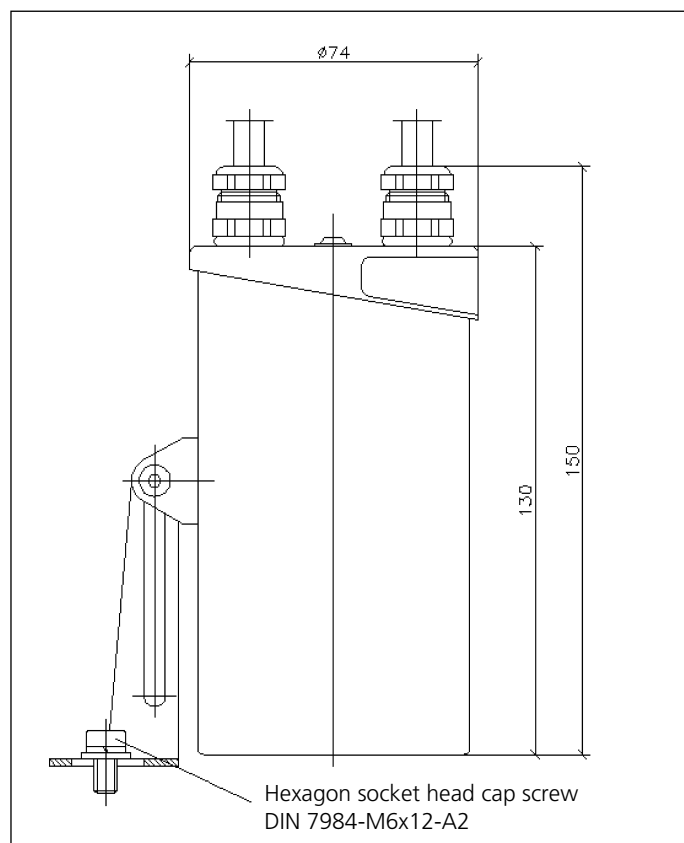

• Order data:

Item	Angle of view	Part No.
1	120°	4502.021.00
2	90°	4502.018.00
3	78°	4502.022.00
4	60°	4502.019.00
5	54°	4502.023.00
6	39°	4502.020.00
7	28°	4502.024.00

**For example:**

VISULEX Camera K15-P-D

- angle of view, see table

- max. 100 m control wire

(please state wire length in full metres)