

SMART3G-C2

with electrochemical sensor

SMART3G-C2 gas detector is designed to meet industrial requirements; the enclosure is explosion proof and can be installed in ATEX Zone 1 and, when equipped with dust adapter, in Zone 21.

The sensing element is placed in the stainless steel head with a 48 mm diameter. The electrochemical cell is used to detect toxic gas, due to the optimal performance in these applications.

The gas detector has a 12-24 Vdc power supply and a standard 4-20 mA 3-wires output. Optionally, the SMART3G-C2 can be equipped with serial RS485 communication and a 1 or 3 relays board .

The aluminium enclosure has dimensions 120 x 184 x 90 mm, with 3 cable entries 3/4" NPT threaded.

The gas detector can be ATEX marked as follows:

CE 0722 Ex II 2G Ex db IIC T5 Gb

Or, when equipped with dust adapter:

CE 0722 Ex II 2GD Ex db IIC T5 Gb
Ex tb IIIC T100°C Db
IP65

The gas detector is IECEx compliant and can be marked as follows:

Ex db IIC T5 Gb

Or, when equipped with dust adapter:

Ex db IIC T5 Gb
Ex tb IIIC T100°C Db
IP65

SMART3G-C2 is SIL2 hardware and SIL3 software; with a redundant system also the hardware is SIL3.



Sensor

Application	Industrial area, ATEX Zone 1 and Zone 21 (when equipped with dust adapter, optional)
Sensing element	Electrochemical cell
Predicted sensor lifetime	2 / 3 years
Gas detected	O ₂ [0-25% Vol], CO [0-500/1000 ppm], NH ₃ [0-100/200/1000/5000 ppm], H ₂ S [0-50/100 ppm], NO [0 - 100 ppm]; H ₂ [0 - 2000/3000 ppm]

Electrical data

Power supply	12-24 Vdc
Output	Analogue 4-20 mA output; 1 or 3 relay board (optional); serial RS485 output (optional)
Maximum dissipated power	5.4 W
Relays contact ratings (optional board)	1.0 A at 24 Vdc
Optical indications	-
Acoustic indications	-
Hall effect sensor	-

Environmental conditions

Storage temperature	0 / +20°C up to 6 months
Operating temperature	-30 / +55°C
Operating humidity	15 / 90% RH non condensing

External case

Material	Enclosure: aluminium pressure die-casting with epoxy paint chromating and chemically resistant Sensor head: stainless steel
Protection mode	Ex d : Explosion proof enclosure Ex t : Equipment dust ignition protection by enclosure (when equipped with dust adapter, optional)
Dimensions	120 x 184 x 90 mm
Weight	1250 g
Cable entries	3 x 3/4" NPT
IP grade	IP65

Compliance

EMC	EN 61000-6-3:2007 + A1:2011; EN 50270:2015
ATEX	ATEX directive 2014/34/EU EN IEC 60079-0:2018 EN 60079-1:2014 EN 60079-31:2014
IECEx	IEC 60079-0:2011 IEC 60079-1:2014 IEC 60079-31:2013
SIL	EN 61508:2010 Parti 1, 2, 3, 4, 5, 6, 7 EN50402:2017



SMART3G-C2

with electrochemical sensor

Product codes

Product codes		ATEX code
S2641O2	Oxygen (0 - 25% Vol) gas detector	ST / L / E3 / S3
S2131CO	CO (0-500 ppm) gas detector	ST / L / E3 / S3
S2131CO-H2	CO (0-500 ppm) gas detector, H2 compensated	ST / L / E3 / S3
S2586CO	CO (0-1000 ppm) gas detector	ST / L / E3 / S3
S3225AM	NH ₃ (0-100 ppm) gas detector	ST / L / E3 / S3
S2133AM	NH ₃ (0-200 ppm) gas detector	ST / L / E3 / S3
S2135AM	NH ₃ (0-1000 ppm) gas detector	ST / L / E3 / S3
S3229AM	NH ₃ (0-5000 ppm) gas detector	ST / L / E3 / S3
S2137HS	H ₂ S (0-50 ppm) gas detector	ST / L / E3 / S3
S3708HS	H ₂ S (0-100 ppm) gas detector	ST / L / E3 / S3
S2145NO	NO (0-100 ppm) gas detector	ST / L / E3 / S3
S3593H2	H ₂ (0-2000 ppm) gas detector	ST / L / E3 / S3
S4547H2	H ₂ (0-3000 ppm) gas detector	ST / L / E3 / S3

Mechanical Drawings

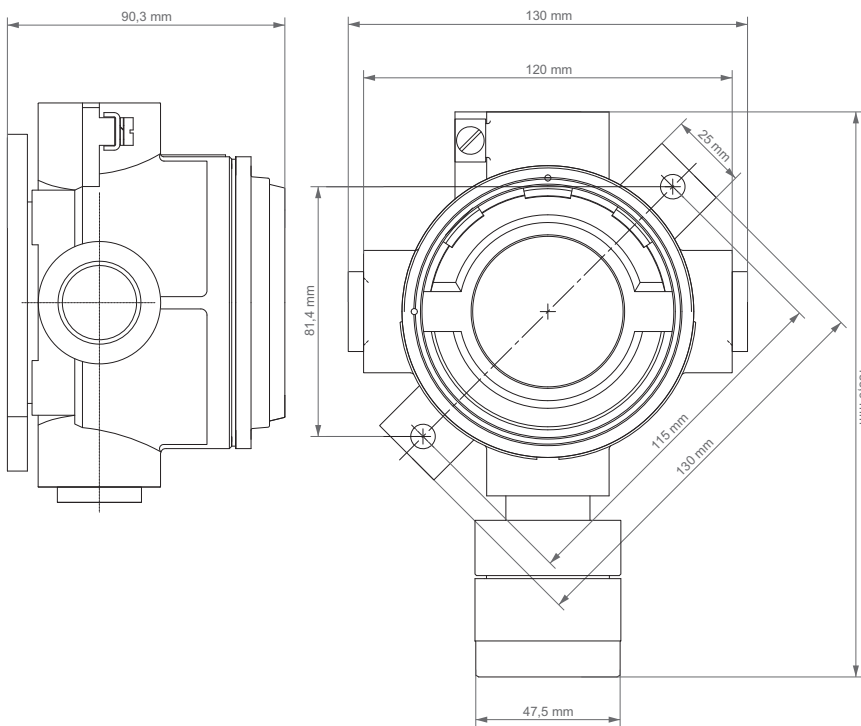

STG/AD3
Dust adapter

