

HCTDT-EU Series of Carbon Dioxide and Temperature Transmitter

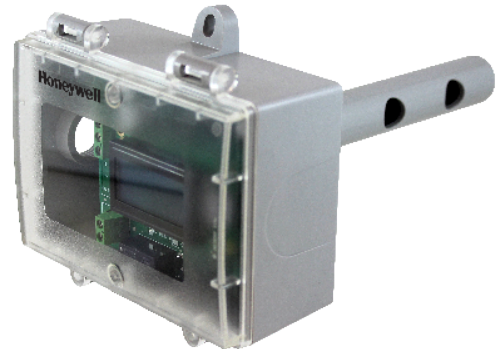

The CO₂/T transmitter incorporates two sensors in one duct mount enclosure for the most efficient environmental monitoring and control system. It uses Infrared Technology to monitor CO₂ levels within a range of 0 – 2000 ppm and a curve-matched thermistor to measure temperature over common field-selectable ranges. Both measurements are continuously available on separate outputs as linear analog signals. The device includes an LCD for configuration and operating parameters are programmed using a keypad for specific applications.

APPLICATIONS

The HCTDT-EU carbon dioxide transmitter is designed for use with commercial heating and cooling systems.

SPECIFICATIONS

Power Supply	20 - 28 Vac/dc (non-isolated half-wave rectified)
Consumptions.....	79 mA max @ 24 Vdc, 129 mA max @ 24 Vac
Output Signals	0-5 Vdc / 0-10 Vdc (field selectable)
Output Drive Capability.....	5 KΩ min for voltage output
Output Resolution.....	10 bit PWM
Input Voltage Effect.	Negligible over specified operating range
Protection Circuitry	Reverse voltage protected, overvoltage protected
Operating Conditions.....	0-50°C (32-122°F), 0-95 %RH non-condensing
LCD Resolution	1 ppm CO ₂ , 1°C or 1°F
LCD Size	35 mm W x 15 mm H (1.4" x 0.6") alpha-numeric 2 line x 8 characters
Wiring Connections	Screw terminal blocks, 14 to 22 AWG
Enclosure.....	Duct mount, Grey polycarbonate with gasket, UL94-V0, IP65 (NEMA 4X) includes thread adapter (1/2" NPT to M16) and cable gland fitting 116.5 W x 112.5 H x 53.7 D mm (4.585" x 4.43" x 2.115")
Probe.....	152 mm L x 22.5 mm D (6" x 0.85")

CO₂ Signal

Measurement Type.....	Non-Dispersive Infrared (NDIR), diffusion sampling
Measurement Range	0-2000 ppm, programmable span
Standard Accuracy	+30 ppm +3% of reading 0-2000 ppm range with Auto Cal
Temperature Dependence.....	0.2 %FS per °C
Stability	2 %FS over life of sensor (15 years typical) Sensor 1 (0-2000 ppm),
Pressure Dependence.....	0.13% of reading per mm Hg
Altitude Correction	Programmable from 0-5000 ft via keypad
Response Time.....	<2 minutes for 90% step change typical
Warm-up Time	<2 minutes
Temperature Signal	
Sensing Element	10K thermistor, +0.2°C (+0.4°F)
Range.....	0 to 35°C (32 to 95°F) or 0 to 50°C (32 to 122°F) selectable via keypad
Resolution.....	0.1°C or 0.1°F
Country of Origin	Canada

HCHDT-EU Series of Carbon Dioxide and Temperature Transmitter

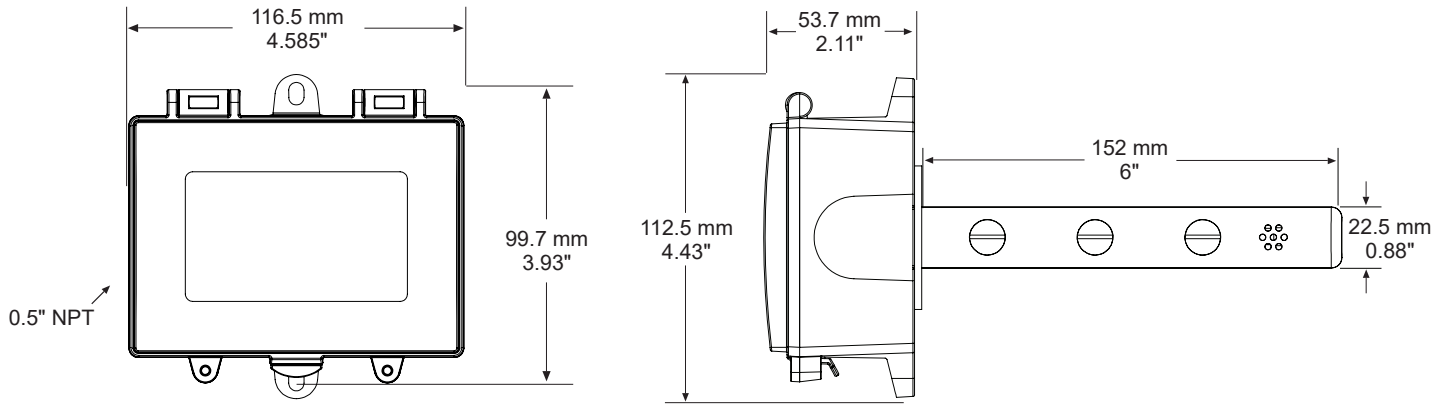

RoHS
COMPLIANT



Honeywell Building Solutions

Honeywell

North America:

1985 Douglas Drive North
Golden Valley, MN 55422-3992
+1-800-345-6770, ext. 606

Europe, Middle East, Africa & India:

Honeywell House
Arlington Business Park
Bracknell, United Kingdom RG12 1EB
+44-(0)1344-656000

North Asia:

Zhang Jiang Hi-Tech Park
No. 430 Li Bing Rd., Pudong New Area,
Shanghai, 201203, China
+86-21-2894-2000

South Asia Pacific:

2 Richardson Place
Sydney NSW 2113
+612-9353-7000

www.honeywell.com



Tlf: 67 150 250 Faks: 67 150 251

Mail: post@instrumentteam.no

Web: www.instrumentteam.no

ORDERING: HCTDTF1VX-EU

Honeywell

Printed on recycled paper containing
15% post-consumer waste.



April 2021
© 2021 Honeywell International Inc.