

Product introduction

Description



Monosilicon pressure transmitter

SMP858 monosilicon pressure transmitter is a high performance pressure transmitter with international leading technology meticulously designed by LEEG instrument, using the world's most advanced monosilicon pressure sensor technology and patent encapsulation technology.

Monosilicon pressure sensor locates on the top of the metal body and stay away from the medium interface to realizes mechanical isolation and thermal isolation. Glass sintering sensor wire realizes high strength electrical insulation of metal base and improves the capability of flexibility of electronic circuit and transient voltage resistance protection.

All these original encapsulation technologies enable SMP858 to easily cope with extreme chemical occasion and mechanical load, and own strong resistance to EMI, sufficient to respond to the most rigorous industrial environment applications, which are the genuine invisible instruments.

Main parameters

Pressure types	Gauge & Absolute pressure
Measuring range	-100kPa ~ 1MPa, minimum range 5kPa
Absolute pressure range	0 ~ 1MPa, minimum range 10kPa
Output signal	4-20mA, 4-20mA+HART, customer
Reference accuracy	±0.1% F.S.

Field of application

Process Industry	Petrochemical, Chemical, Power, Steel, Cement, Papermaking
------------------	--

Approvals

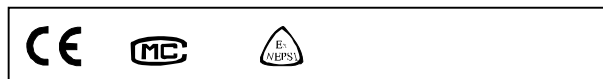

Measuring medium

Normal medium	Gas, Steam, Liquid
Special medium	The fluids which compatible with wetted parts

**Performance Parameter**

**Measuring range and limit**

Nominal value	Smallest calibratable span	Lower range limit(LRL)	Upper range limit(URL)	Overload limit
40kPa	2kPa	-40kPa	40kPa	1MPa
250kPa	12.5kPa	-100kPa	250kPa	4MPa
1MPa	50kPa	-100kPa	1MPa	6MPa

Above measurement range can be replaced by kg/cm2, MPa and kPa units .Which can provide other measurement range according to the requirements. Adjust requirements: lower range value (LRV) and upper range value (URV) can be adjusted within the scope of the upper and lower range limit, smallest calibratable span ≤ | URV-LRV | ≤ upper range limit

**Performance Parameter**

Performance reference JIG882-2004 calibration conditions, 4 ~ 20mA+HART two wires analog signal output. The range is calibrated against the standard zero point. Silicon oil filling, 316L stainless steel isolation diaphragm.

Static Effects	
Zero Effect	± (0.1% * Nominal range (URL) + 0.1% * Nominal range / 10MPa. Available elimination parameters on site
Range Effect	± (0.15% * Nominal range (URL)/ 10MPa.

Responds Time	150mS
Stability	±0.15%URL/ 24 Months

**Nominal range: 6kPa**

Reference accuracy		
Linear output	Standard	Linearity, hysteresis start from zero ±0.1% Range
	Range adjustment	The range ratio (TD)= Nominal range/ Range, TD>4 ±[0.05+0.0125(URL/Range ) ]% Range
Square root output	1.5 times of above linear reference output accuracy.	

**Nominal range: 35kPa 100kPa 250kPa 1000kPa**

Reference accuracy		
Linear output	Standard	Linearity, hysteresis start from zero ±0.075% Range
	Adjustment range	The range ratio (TD)= Nominal range/ Range, TD>10 ±0.02(URL/Range)%Range
Square root output	1.5 times of above linear reference output accuracy.	

Ambient temperature effects (Calibration Temperature: 25°C)	
-20 ~60°C	TD<4, ± ( 0.02%* Nominal range (URL) +0.075%* range)/20°C
	TD>4, ± ( 0.03%* Nominal range (URL) +0.15%* range)/20°C
Others	TD<4, ± ( 0.04%* Nominal range (URL) +0.25%* range)/20°C
	TD>4, ± ( 0.06%* Nominal range (URL) +0.4%* range)/20°C

Ambient temperature effects (Calibration Temperature: 25°C)	
-20 ~60°C	TD>10, ± ( 0.02%* Nominal range (URL) +0.075%* range)/20°C
	TD>10, ± ( 0.03%* Nominal range (URL) +0.2%* range)/20°C
Others	TD<10, ± ( 0.04%* Nominal range (URL) +0.3%* range)/20°C
	TD<10, ± ( 0.06%* Nominal range (URL) +0.5%* range)/20°C

Responds time	150mS
Stability	±0.1%URL/ 36 Months

Installation position influence

Any position installation, the maximum value < 400Pa, and can be eliminated to 0

Vibration effects

Test standard: IEC61298-3, <0.1% URL

Power supply effects

Power supply 20~30VDC, Load value ≤300Ω, 0.001% URL /10v

Loading effects

Power supply 20~30 VDC, Load value 0~800Ω, Accuracy effect value < 0.005%URL

Menu function

Transmission module type

Output signal	Local control	Local control
4-20mA+HART	LCD/3 buttons on body	HART
4-20mA	LCD/3 buttons on body	-

The menu functions operated by the external buttons or the three buttons of integrated display or with HART supporting software and communication demodulator. Without the integration of LCD and HART, the same with these functions, but the operation will be limited.

LCD display unit

Display mode	Details
PV	Process variable shows on main screen, percentage and progress bar shows on secondary screen
mA	Current shows on main screen, percentage and progress bar shows on secondary screen
%	Percentage shows on main screen, percentage and progress bar shows on secondary screen

Range

Nominal range	SLH SLL / Range		Minimum Range
	URL	LRL	
*Note: Range of pressure from SLL to full-point SLH should be greater than the applicable minimum range			

Damping time

Units	Setting range
S	0.1 ~ 32.000 S
*Note: The response time of the signal output relative to the input step change. The damping time of the micro pressure range is longer. The overall response time includes the set damping value and the response time.	

Unit

Unit	Definition
kPa	Kilopascal
MPa	Megapascals
bar	Bar
psi	Pounds per square inch
mmHg	Millimetre(s) of mercury@0°C
mmH2O	Millimeter of water@4°C
mH2O	Meter of water@4°C
inH2O	Inches of water@4°C
ftH2O	Feet of water@4°C
inHg	Inches of mercury@0°C
mHg	Meter mercury column@0°C
TORR	Torr
mbar	Millibar
g/cm2	Gram per square centimeter
kg/cm2	Kilogram per square centimeter
Pa	PA
ATM	Standard atmospheric pressure
mm	Millimeter(Note1)
m	Meter(Note1)
g/cm3	Gram per cubic centimeter
m/S	Meter/ Seconds
Note: associated unit according to the need to transmitting module automatically range conversion	

Output type

Parameters	Output type
LINER	Linearity
*SQRT	Square root
Note, this function is often used in flow measurement and other function switch.	

Alarm signal

Parameters	Alarm signal output value
ALARM NO	None
ALARM H	20.8mA
ALARM L	3.8mA
*Note, the fault alarm signal for the transmitter self-diagnosis, Optional: A low current of 3.8mA or a high current 20.8mA fixed output to warn	

Fix output

Parameters	Fix output value
FIX/C NO	None
3.8000	3.8000mA
4.0000	4.0000mA
8.0000	8.0000mA
12.000	12.000mA
16.000	16.000mA
20.000	20.000mA
20.800	20.800mA
*Note, refers to the transmitter signal output and the host computer signal input calibration, used in field under the errors diagnosis in electromagnetic interference and excessive cable resistance	

Quick menu

Parameter	Instruction
PV=0	Set current output to zero value, used to correct the error caused by static pressure and installation.
Zero adjustment	Set current pressure value is zero, used in field under the condition of the zero adjustment
Span adjustment	Set current pressure value is zero, used in field under the condition of the zero adjustment
Restore factory setting	Restore backup data when error

Environment condition

Items	Operation condition
Working temperature	-40-85°C, integrated LCD display:-20-70°C
Storage temperature	-40-110°C, integrated LCD display:-40-85°C
Media temperature	Silicon oil filling: -40-80°C,-40-70°C, under vacuum environment,
	Fluorocarbon oil filling: -10-80°C, -10-60°C, under vacuum environment
Working humidity	0-95%RH
Protection class	IP67
Dangerous condition	Reference dangerous places license

Power supply

Type	Operation condition
Standard	10.5~55 VDC
Transient resistance module	10.5~55 VDC
Intrinsic safety	12~30 VDC
HART communication protocol	16.5~55 VDC, load resistance 250Ω
Load resistance	(Power supply 10 VDC) / 22mA
Transmission distance	4~20mA, 4~20mA + HART about 1000m
Power consumption	≤50mW

Pressure limit

Nominal range	Overload
All range	1.5 times overload or depends on maximum pressure value of process connection

EMC Environment

Standard	Emission requirements in line with the 61000-6-3, protection requirements and test accord with ENEN61000-6-2
Radio frequency protection	30V/m(1000-4-3 , 61000-4-3)
Conduction protection	30V ( 1000-4-6 , 61000-4-6 )

Vibration environment

Vibration resistance	Up to 2 g acceleration and highest frequency to 1000 hz (IEC 60068-2-6)
Impact resistance	Acceleration, 50 g; Duration of 11 ms IEC (60068-2-27)

Other

Turn-on time	2S, Meeting parameter index
--------------	-----------------------------

**Product selection instruction**

**Sensor type**

Code	Type	Description
G	Pressure sensor type	Gauge pressure type
A		Absolute pressure type
N		High vacuum occasions (Measuring absolute pressure value <20kPa)
F	Seal way	Stainless steel welding seal

**Range code**

Code	Nominal value	Description
S602	6kPa	Nominal value: 6kPa, smallest value 5kPa
S353	35kPa	Nominal value: 35kPa, smallest value 10kPa
S104	100kPa	Nominal value: 100kPa, smallest value 50kPa
S254	250kPa	Nominal value: 250kPa, smallest value 100kPa
S105	1000kPa	Nominal value: 1000kPa, smallest value 500kPa

Note: Absolute pressure sensor minimum nominal value: 35 kPa, Gauge pressure sensor LRL: -100 kPa, Absolute pressure sensor LRL: 0kPa

**Electrical connection**

Code	Item	Description
T1	Electrical connection	Aluminum-alloy terminal, 2 cable entry M20*1.5(F), red body, white cover
R1	Cable entry protector	Waterproof connector M20X1.5 one side, blind plug another side, PVC material, 6-8mm diameter cable only, IP67
R2		Flame proof, 1/2 NPT(F) one side, blind plug another side, stainless steel material, 6-8mm diameter cable only, IP67
R3		Flame proof, M20X1.5(F) one side, blind plug another side, stainless steel material, 6-8mm diameter cable only, IP67

**Housing(T1)**

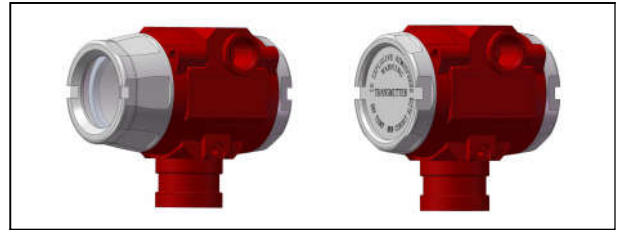

**Standard cable entry protective adaptor(R1)**

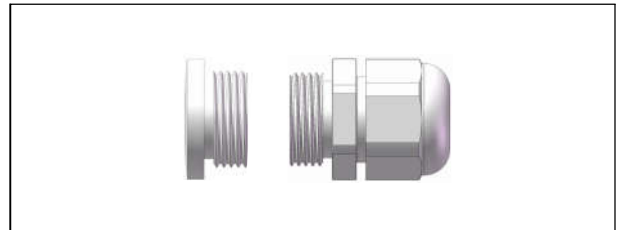

**Flame proof cable entry protective adaptor(R2/R3)**

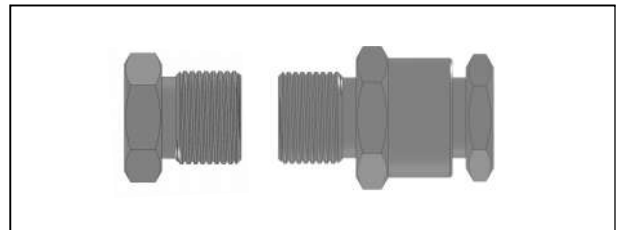

**Product selection instruction**

**Transmission module**

Code	Items	Description
F	Output signal	4-20mA two wire, power supply: 10.5-55VDC
H		4-20mA+HART two wire, power supply: 16.5-55VDC
A	Display	Without display
C		With LCD display

**Display module (C)**



**Terminals**

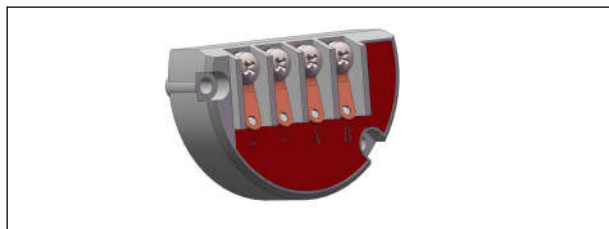

**Isolation diaphragm**



**Process connection select instruction**

Code	Items	Description
4	Process connector material	Stainless steel, SUS304
6		Stainless steel, SUS316
NT	Connection type	Standard connection, medium temperature: -25-85°C
HT		With Cooling Element, suitable for medium temperature -40-150°C
UT		With Capillary Element, suitable for medium temperature -40-300°C
S	Isolation fluid filling	Silicon oil, process temperature: -45-205°C
H		High-temperature silicon oil, process temperature: 0-315°C
S	Isolation diaphragm material	Stainless steel, SUS316L
T		Tantalum
P		SUS316 + PTFE cover
H		Hastelloy alloy C
8		Tantalum + PTFE cover
9	Hastelloy C + PTFE cover	

Product drawing and dimension

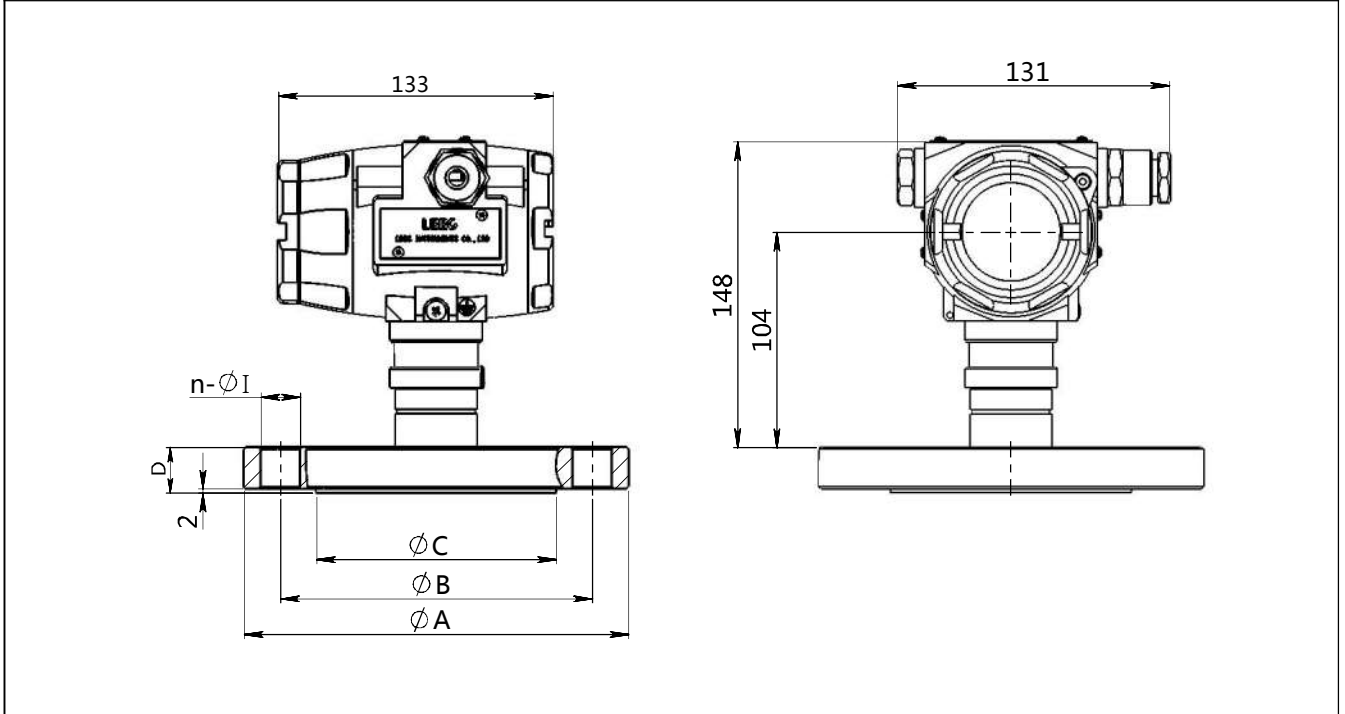

Flange Drawing and Dimension

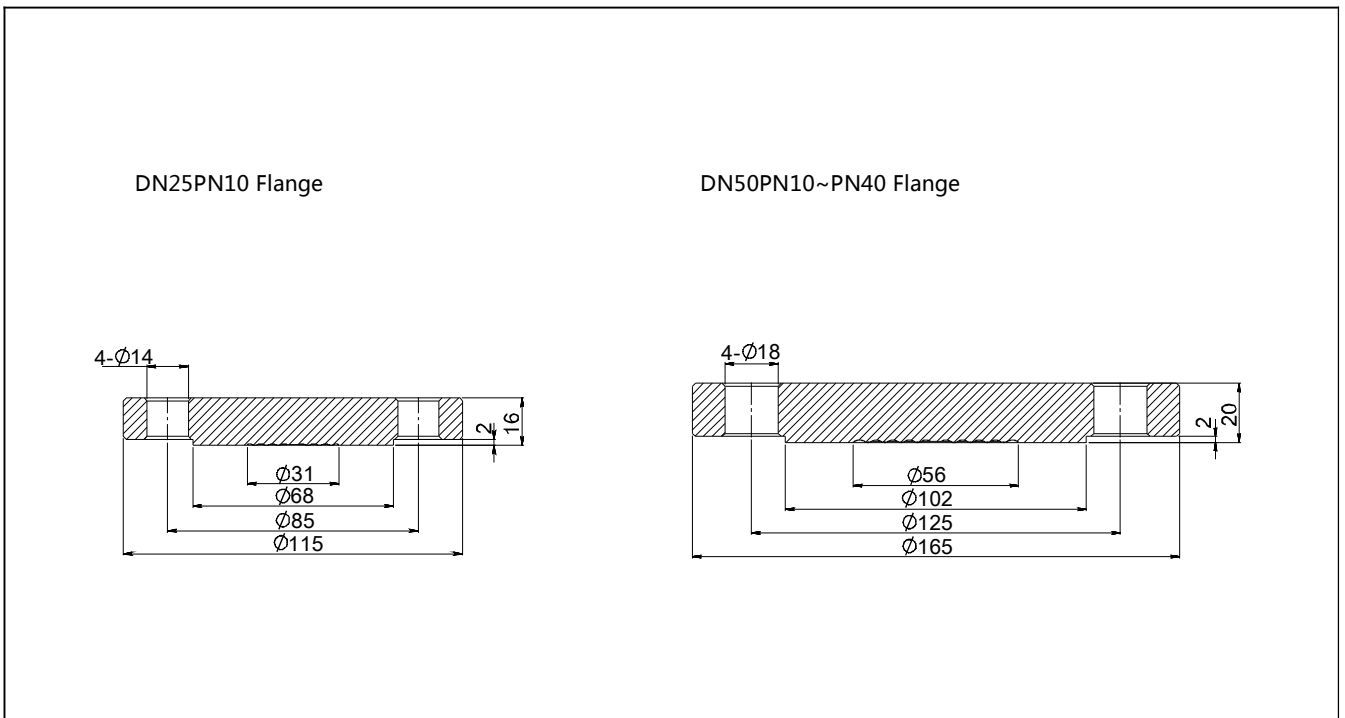

Disclaimer: all the data used in the product description is not legally binding. Relevant technical details may be changed due to further improve



**Ordering information chapter**

Item	Parameters	Code	Instruction	(*) fast delivery available
	Model	SMP858-TST	Monosilicon diaphragm pressure transmitter	
Sensor	Separator	-	Detailed specifications as following	
	Pressure range code	S602G	Nominal value: 6kPa	
		S353G	Nominal value: 35kPa	*
		S104G	Nominal value: 100kPa	*
		S254G	Nominal value: 250kPa	*
		S105G	Nominal value: 1000kPa	
	Pressure type	G	Gauge pressure type	*
		A	Absolute pressure type	*
		N	High vacuum occasions ( Measuring absolute pressure value <20kPa )	
Sensor seal	F	Stainless steel welding seal	*	
Electrical connection	Separator	-	Detailed specifications as following	
	Electrical connection	T1	Aluminum-alloy terminal,2 cable entry M20*1.5(F), red body, white cover	*
	Cable entry protector	R1	Waterproof connector M20X1.5 one side , blind plug another side, PVC material,6-8mm diameter cable only, IP67	*
		R2	Flame proof, 1/2 NPT(F) one side, blind plug another side, stainless steel material, 6-8mm diameter cable only, IP67	*
		R3	Flame proof, M20X1.5(F) one side, blind plug another side, stainless steel material, 6-8mm diameter cable only, IP67	*
Output	Separator	-	Detailed specifications as following	
	Output signal	F	4-20mA two wire, power supply: 10.5~55VDC	*
		H	4-20mA+HART two wire, power supply: 16.5~55VDC	*
	Display	C	LCD display	*
		A	Without LCD display	*
Process connection	Separator	-	Detailed specifications as following	
	Process connector material	4	Stainless Steel SUS304	*
		6	Stainless steel SUS316	*
	Connection type	NT	Standard connection, suitable for medium temperature -25-85°C	*
		HT	With Cooling Element, suitable for medium temperature -40-150°C	*
		UT	With Capillary Element, suitable for medium temperature -40-300°C	*
	Isolation fluid filling	S	Silicon oil, process temperature: -45-205°C	*
		H	High-temperature silicon oil, process temperature: 0-315°C	*

## Ordering information chapter

	Isolation diaphragm material	S	SUS316L	*
		T	Tantalum	
		P	SUS316 + PTFE cover	
		H	Hastelloy C	*
		8	Tantalum + PTFE cover	
		9	Hastelloy C + PTFE cover	
	Process connection specifications	H01	HG/T 20592-2009 DN50PN10 Flange	*
		H02	HG/T 20592-2009 DN25PN10 Flange	*
Additional options	Separator	-	Detailed specifications as following	
	Display mode	/D1	According to your requirement	*
	Calibration report	/Q1	Calibration report provide by our company	*
		/Q2	Calibration report provide by chinese authorised third party	*
	Approvals	/E1	Flame proof certificate, ExdIICT6, NEPSI	*
		/I1	Intrinsic safety certificate, ExialICT4, NEPSI	*
		/F3	CE certificate	*
	Wetted parts treatment	/G1	Ungrease treatment	*
/G2		Electropolishing treatment	*	

**Factory settings and parameters**

Item	Menu mark	Factory setting value
Tag position	None	0(No specific settings)
Analog output type	mA	Liner
Display mode	DISP	PV
Alarm signal	ALARM	No

Item	Menu mark	Factory setting value
Damping value	DAMP	0(No specific settings)
4mA Lower range value	LRV	According to the order value
20mA Upper range value	URV	According to the order value
Process unit	U	According to the order

**Approvals**

**Factory certificate**

Certification organization	Intertek
Quality management system	ISO9001-2008
Scope of certification	Design and production of pressure transmitter
Registration number	110804039

**Intrinsic safety certificate**

Certification organization name	NEPSI
License scope	SMP858 series pressure transmitter
Explosion-proof mark	ExialICT4
Ambient temperature	-40-+60°C
Medium maximum temperature	+120°C
Registration number	GYB16.1965X
Intrinsically safe parameter description	Maximum input voltage: 28VDC
	Maximum input current: 100mA
	Maximum input power: 0.7w
	Maximum internal equivalent parameters Ci(uF): 0 Maximum internal equivalent parameters Li(mH): 0.01

**CE**

Certificate organization	ISET
License scope	SMP858 series pressure transmitter
Mark	CE
EMC instruction	2014/30/EU
Standard	EN61326-1: 2013
Registration number	IT051353LG161207

**Flame proof certificate**

Certification organization	NEPSI
License scope	SMP858 pressure transmitter
Explosion-proof mark	ExdIICT6
Working environmental temperature	-25-+60°C
Maximum medium temperature	+80°C
Registration number	GYB16.1253X



scan & follow LEEG wechat



check website for more info



Tlf: 67 150 250 Faks: 67 150 251  
Mail: post@instrumentteam.no  
Web: www.instrumentteam.no