

### STR700 SmartLine Remote Diaphragm Seals Specification 34-ST-03-124, Jan 2022



#### Introduction

Part of the SmartLine® family of products, the STR700 is a series of pressure transmitters hydraulically matched and optimized with a complete set of remote diaphragm seals. Utilizing the same high performance sensor technology of the ST 800 product line Honeywell has optimized the mechanical and hydraulic designs to minimize the typical effects of temperature on remote seal systems. The SmartLine family is also fully tested and compliant with Experion® PKS providing the highest level of compatibility assurance and integration capabilities. SmartLine easily meets the most demanding application needs for pressure measurement applications.

- Accuracies up to 0.075% of span
- Automatic static pressure & temperature compensation
- Rangeability up to 100:1
- Easy to use and intuitive display capabilities
- Intuitive External zero, span, & configuration capability
- Comprehensive on-board diagnostic capabilities
- Integral Dual Seal design for highest safety based on ANSI/NFPA 70-202 and ANSI/ISA 12.27.0
- World class overpressure protection
- Full compliance to SIL 2/3 requirements.
- Modular design characteristics



**Figure 1 – STR700 Remote Diaphragm Seal Unit with feature field-proven piezoresistive sensor technology**

#### Typical Diaphragm Seal applications

- High Process Temperatures
- Viscous or Suspended Solids
- Highly Corrosive Process Materials
- Sanitary Applications
- Applications with Hydrogen Permeation Possibilities
- Level Applications with Maintenance Intensive Wet Legs
- Applications requiring remote Transmitter Mounting
- Tank Applications with Density or Interface Measurements

#### Span & Range Limits:

Model	URL psid (bar)	LRL psid (bar)	Min Span psid (bar)
STR735D	100 (7.0)	-100 (-7.0)	0.9 (0.062)
Model	psig (bar)	psig (bar)	psig (bar)
STR745G	500 (35.0)	-14.7 (-1.0)	5 (0.35)

#### Communications/Output Options:

- HART® (version 7.0)

## Description

The SmartLine family pressure transmitters are designed around a high performance piezo-resistive sensor. This one sensor actually integrates multiple sensors linking process pressure measurement with on-board static pressure (DP Models) and temperature compensation measurements.

## Indication/Display Option

### Standard LCD Display Features

- Modular (may be added or removed in the field)
- Supports HART protocol variant
- 0, 90, 180, & 270 degree position adjustments
- Configurable (HART only) and standard (Pa, KPa, MPa, KGcm<sup>2</sup>, Torr, ATM, mH<sub>2</sub>O, bar, mbar, inH<sub>2</sub>O, inHG, FTH<sub>2</sub>O, mmH<sub>2</sub>O, mm HG, & psi) measurement units.
- Supports Flow engineering units
- 2 Lines 6 digits PV (9.95H x 4.20W mm) 8 Characters
- Square root output indication (√)
- Write protect Indication
- Built in Basic Device Configuration through Internal Buttons – Range/Engineering Unit/Loop Test /Loop Calibration/Zero /Span Setting
- Multiple language capability (EN, RU)

## Diagnostics

SmartLine transmitters all offer digitally accessible diagnostics which aid in providing advanced warning of possible failure events minimizing unplanned shutdowns, providing **lower overall operational costs**

## System Integration

- SmartLine communications protocols all meet the most current published standards for HART.
- All ST 700 units are Experion tested to provide the highest level of compatibility assurance

## Configuration Tools

### External Two Button Configuration Option

Suitable for all electrical and environmental requirements, SmartLine offers the ability to configure the transmitter and display, for all basic parameters, via two externally accessible buttons when a display option is selected. Zero/span capabilities are also optionally available via two external buttons with or without selection of the display option.

### Internal Two Button Configuration Option

The Standard display has two buttons that can be used for Basic configuration such as re ranging, PV Engineering unit setting, Zero/Span settings, Loop testing and calibration functions.

### Handheld Configuration

SmartLine transmitters feature two-way communication and configuration capability between the operator and the transmitter. All Honeywell transmitters are designed and tested for compliance with the offered communication protocols and are designed to operate with any standards compliant handheld configuration device.

### Personal Computer Configuration

Field Device Manager (FDM) Software and FDM Express are also available for managing HART configurations.

## Modular Design

To help contain maintenance & inventory costs, all ST 700 transmitters are modular in design supporting the user's ability to replace meter bodies, standard displays or electronic modules without affecting overall performance. Each meter body is uniquely characterized to provide in-tolerance performance over a wide range of application variations in temperature and pressure.

### Modular Features

- Meter body replacement
- Add or remove standard displays
- Add or remove lightning protection (terminal connection)

With no performance effects, *Honeywell's unique modularity results in lower inventory needs and lower overall operating costs.*

**Performance Specifications**

Reference Accuracy (conformance to +/-3 Sigma)

**Table 1**

Model	URL	LRL	Min Span	Maximum Turndown Ratio	Reference Accuracy <sup>1,2</sup> (% Span) Standard
STR735D	100 psi (7.0 bar)	-100 psi (-7.0bar)	0.9 psi (0.062bar)	111:1	0.075
STR745G	500 psi (35 bar)	-14.7 psi (-1.0 bar)	5 psi (0.035 bar)	100:1	0.075/0.040

**Table 2**

		Accuracy <sup>1,2</sup> (% of Span)				Combined Zero & Span temperature Effect (% Span / 28°C (50°F))			
	Model	URL	Reference Turndown	A	B	C (see URL units)	D	E	F
Standard Accuracy	STR735D	100 psi (7.0 bar)	22:1	0.005	0.060	4.52 (0.311)	0.275	1.200	9 (0.622)
	STR745G	500 psi (35 bar)	20:1			25 (1.75)			
High Accuracy Option	STR745G	500 psi (35 bar)	20:1	0.005	0.035	25 (1.75)			
<b>Turn Down Effect</b>						<b>Temperature Effect</b>			
$\pm [A + B] \text{ if Span} \geq C$ $\pm \left[ A + B \left( \frac{C}{\text{Span}} \right) \right] \text{ if Span} < C$						$\pm \left[ D + E \left( \frac{F}{\text{Span}} \right) \right]$			
						$\pm \left[ A + B \left( \frac{F}{\text{Span}} \right) \right] \text{ if Span} < F$			

Accuracy at Specified Span, Temperature and Static Pressure: (conformance to +/-3 Sigma)

Total Performance (% of Span):

Total Performance = +/-  $\sqrt{(\text{Accuracy})^2 + (\text{Temp Effect})^2}$

**Total Performance Examples (for comparison):** (standard accuracy, 5:1 Turndown, up to 50 °F (28°C) shift)  
**STR735D @ 20 psid:** 1.476% of span

**Typical Calibration Frequency:**

Calibration verification is recommended every four (4) years

**Notes:**

1. Terminal Based Accuracy – Includes combined effects of linearity, hysteresis, and repeatability. Analog output adds 0.006% of span.
2. For zero based spans and reference conditions of 25°C (77°F), 0 psi static pressure for DP, >= 0 psia for GP, 10 to 55% R.H, and 316 Stainless Steel barrier diaphragms

**Operating Conditions – All Models**

Parameter	Reference Condition (at zero static)		Rated Condition		Operative Limits		Transportation and Storage	
	°C	°F	°C	°F	°C	°F	°C	°F
<b>Ambient Temperature<sup>1</sup></b>	25±1	77±2	-	-	-	-	-55 to 90	-67 to 194
<b>Humidity %RH</b>	10 to 55		0 to 100		0 to 100		0 to 100	
<b>Vacuum Region, Minimum Pressure mmHg absolute</b>	Atmospheric (See Figure 4 for vacuum limitation)							
<b>Supply Voltage, Current, and Load Resistance</b>	10.8 to 42.4 V DC at terminals (IS versions limited to 30 VDC) 0 to 1,440 ohms (as shown in Figure 2)							
<b>Maximum Allowable Working Pressure (MAWP)<sup>2</sup></b> (ST 700 products are rated to Maximum Allowable Working Pressure. MAWP depends on Approval Agency and transmitter materials of construction.)	MAWP is minimum of Body Rating or Seal Rating (See Model Selection Guide for Seal MAWP) <b>Body MAWP</b> STR735D 750 psig (51.7 bar) Bolted Process Heads STR745G 500 psig (35 bar)							

<sup>1</sup> Ambient Temperature Limit is a function of Process Interface Temperature. (See Figures 3 & 4)  
 LCD Display operating temperature -20°C to +70°C . Storage temperature -30°C to 80°C

<sup>2</sup> Consult factory for MAWP of ST 700 transmitters with CRN approval.

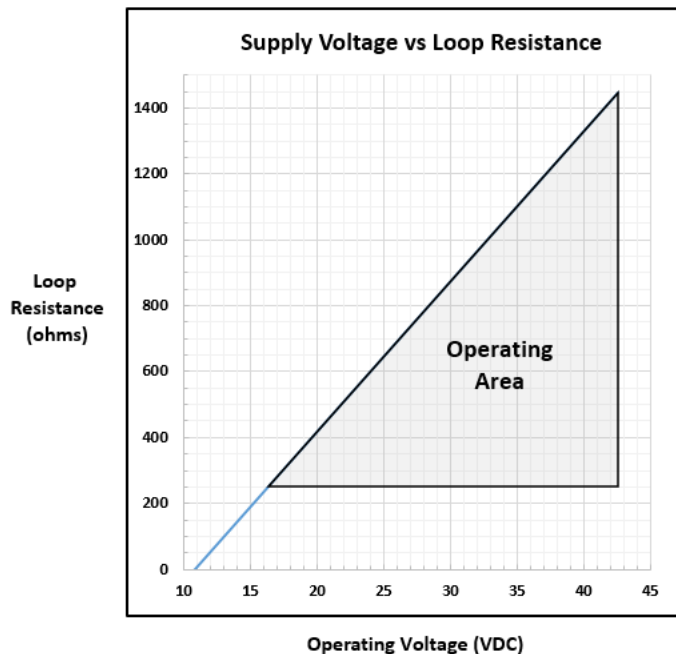

A minimum of 250 ohms loop resistance is required to support field communicator, where Loop resistance is the summation of barrier resistance, wire resistance and receiver resistance

Maximum loop resistance  
 $RL_{max} = 45.6 \times (\text{Power Supply Voltage} - 10.8)$

**Figure 2 – Supply voltage and loop resistance**

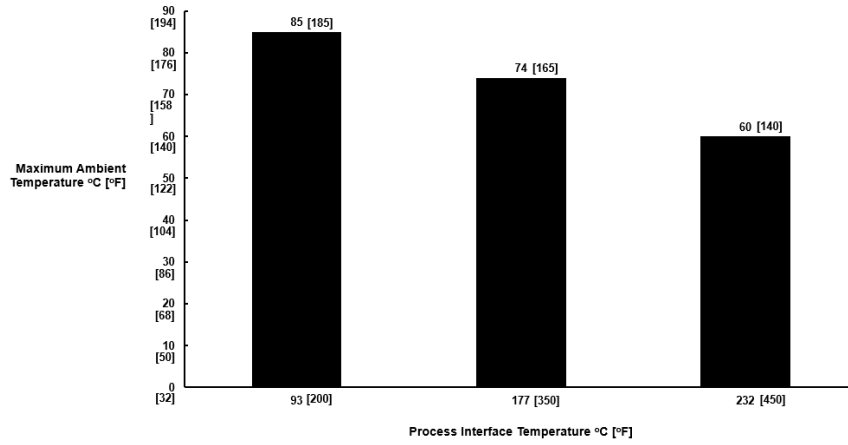

Figure 3- Ambient Temperature Limits

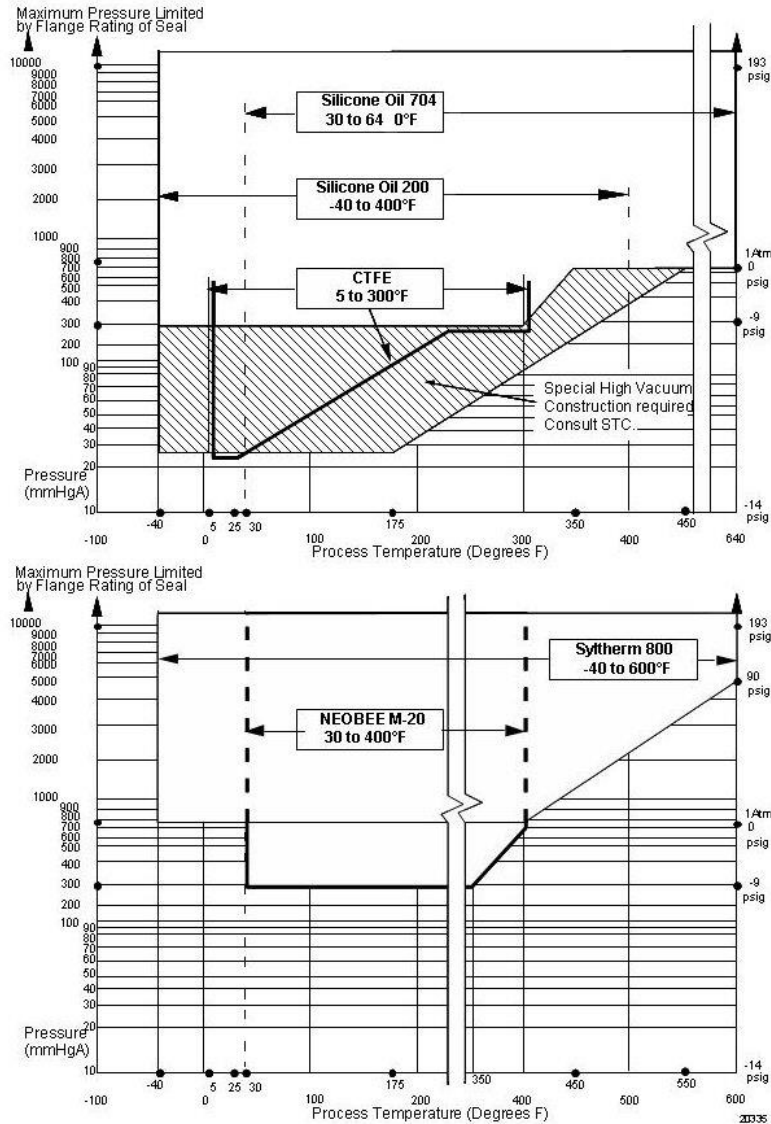

Figure 4 - STR700 Remote Seals operable limits for pressure vs. temperature

**Performance Under Rated Conditions – All Models**

Parameter	Description									
Analog Output	Two-wire, 4 to 20 mA									
Digital Communications:	HART protocol									
HART Output Failure Modes	<table border="0"> <thead> <tr> <th></th> <th>Honeywell Standard</th> <th>NAMUR NE 43 Compliance</th> </tr> </thead> <tbody> <tr> <td><b>Normal Limits:</b></td> <td>3.8 – 20.8 mA</td> <td>3.8 – 20.5 mA</td> </tr> <tr> <td><b>Failure Mode:</b></td> <td>≤ 3.6 mA and ≥ 21.0 mA</td> <td>≤ 3.6 mA and ≥ 21.0 mA</td> </tr> </tbody> </table>		Honeywell Standard	NAMUR NE 43 Compliance	<b>Normal Limits:</b>	3.8 – 20.8 mA	3.8 – 20.5 mA	<b>Failure Mode:</b>	≤ 3.6 mA and ≥ 21.0 mA	≤ 3.6 mA and ≥ 21.0 mA
	Honeywell Standard	NAMUR NE 43 Compliance								
<b>Normal Limits:</b>	3.8 – 20.8 mA	3.8 – 20.5 mA								
<b>Failure Mode:</b>	≤ 3.6 mA and ≥ 21.0 mA	≤ 3.6 mA and ≥ 21.0 mA								
Supply Voltage Effect	0.005% span per volt									
Transmitter Turn on Time (includes power up & test algorithms)	2.5 seconds									
Damping Time Constant	Adjustable from 0 to 32 seconds in 0.1 increments. <b>Default:</b> 0.50 seconds									
Electromagnetic Compatibility	IEC 61326-3-1									
Lightning Protection Option	<b>Leakage Current:</b> 10uA max @ 42.4VDC 93C <b>Impulse rating:</b> 8/20us      5000A (>10 strikes)      10000A (1 strike min.) 10/1000us      200A (> 300 strikes)									

**Materials Specifications (see model selection guide for availability/restrictions with various models)**

Parameter	Description
Process Interface	See Model Selection Guide for Material Options for desired seal type.
Seal Barrier Diaphragm	316L Stainless Steel, Monel®, Hastelloy® C, Tantalum
Seal Gasket Materials	Klinger C-4401 (non-asbestos)      Grafoil®, Teflon®, Gylon 3510®
Mounting Bracket	Carbon Steel (Zinc-Chromate plated) or 304 Stainless Steel or 316 Stainless Steel.
Fill Fluid (Meter Body)	Silicone 200      S.G. @ 25°C = 0.94 CTFE (Chlorotrifluoroethylene)      S.G. @ 25°C = 1.89
Fill Fluid (Secondary)	Silicone 200      S.G. @ 25°C = 0.94 CTFE (Chlorotrifluoroethylene)      S.G. @ 25°C = 1.89 Silicone 704      S.G. @ 25°C = 1.07 Syltherm 800®      S.G. @ 25°C = 0.90 NEOBEE M-20®      S.G. @ 25°C = 0.93
Electronic Housing	Pure Polyester Powder Coated Low Copper (<0.4%)-Aluminum. Meets NEMA 4X, IP66, & P67. All stainless steel housing is optional.
Capillary Tubing	<b>Material:</b> Armored Stainless Steel or PVC Coated Armored Stainless Steel. <b>Length:</b> 5, 10, 15, 20, 25, and 35 feet (1.5, 3, 4.6, 6.1, 7.5, and 10.7 meters). A 2 inch (51 millimeter) S.S. close-coupled nipple is also available. See Model Selection Guide. Refer to <a href="#">Table 3</a> for guide to maximum capillary length vs. diaphragm diameter. Note: The minimum span is the higher of the higher of the value from the table above or the value defined under the Performance Conditions for the range transmitter.
Wiring	Accepts up to 16 AWG (1.5 mm diameter)
Mounting	See <a href="#">Figure 5</a>
Dimensions	<b>Transmitter:</b> <a href="#">Figure 6</a> and <a href="#">Figure 7</a> <b>Seal:</b> <a href="#">Figure 8</a> through to <a href="#">Figure 13</a>
Net Weight	<b>Transmitter:</b> 8.3 pounds (3.8 Kg). With Aluminum Housing. Total weight is dependent on seal

**NOTE:** Pressure transmitters that are part of safety equipment for the protection of piping (systems) or vessel(s) from exceeding allowable pressure limits, (equipment with safety functions in accordance with Pressure Equipment Directive 97/23/EC article 1, 2.1.3), require separate examination.

**MINIMUM RECOMMENDED SPAN FOR STR735D TRANSMITTER WITH TWO SEALS**

Diaphragm Size (Inch)	Capillary Length (Feet)						Maximum Capillary Length (Feet)
	5	10	15	20	25	35	
1.9	15 psi	20 psi	25 psi	-	-	-	15
2.4	5.4 psi	7.2 psi	9.0 psi	10.8 psi	12.6 psi	14.4 psi	35
2.9	1.8 psi	2.7 psi	3.6 psi	4.5 psi	5.4 psi	7.2 psi	35
3.5	0.9 psi	0.9 psi	0.9 psi	1.0 psi	1.2 psi	1.4 psi	35
4.1	0.9 psi	0.9 psi	0.9 psi	0.9 psi	0.9 psi	1.1 psi	35

**MINIMUM RECOMMENDED SPAN FOR STR745G AND STR735D TRANSMITTER WITH ONE REMOTE SEAL**

Diaphragm Size (Inch)	Direct Mount	Capillary Length (Feet)						Maximum Capillary Length (Feet)
		5	10	15	20	25	35	
1.9	25 psi	30 psi	40 psi	50 psi	-	-	-	15
2.4	10 psi	15 psi	20 psi	25 psi	30 psi	35 psi	50 psi	35
2.9	8 psi	9 psi	10 psi	11 psi	12 psi	13 psi	15 psi	35
3.5	2 psi	2 psi	3 psi	4 psi	5 psi	6 psi	8 psi	35
4.1	0.9 psi	0.9 psi	1 psi	2 psi	3 psi	3.5 psi	5 psi	35

**Note:** The minimum span is the higher of the higher of the value from the table above or the value defined under the Performance Conditions for the range transmitter.

**Table 3 – Typical Maximum capillary length and diaphragm size chart**

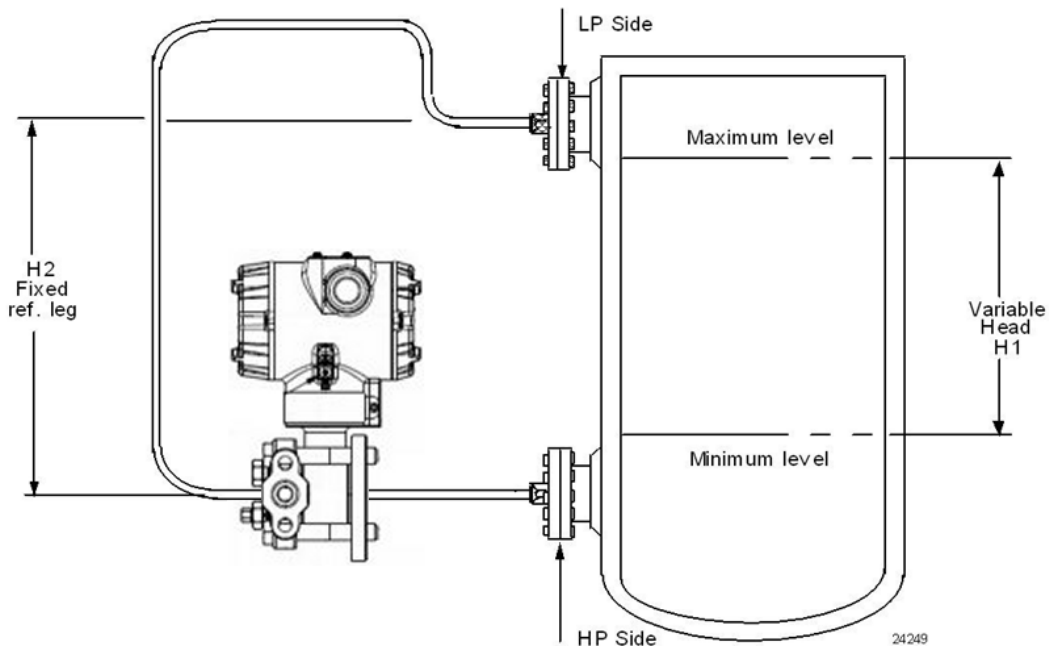

NOTE: Lower flange seal should not be mounted over 22 feet below or above the transmitter for silicone fill fluid (11 feet for CTFE fill fluid) with tank at one atmosphere. The combination of tank vacuum and high pressure capillary head effect should not exceed 9 psi vacuum (300 mmHg absolute).

Consult Honeywell for installation of STR735D

**Figure 5 - STR700 transmitter with remote diaphragm seals shown mounted on a tank**

Reference Dimensions Horizontal Mounting

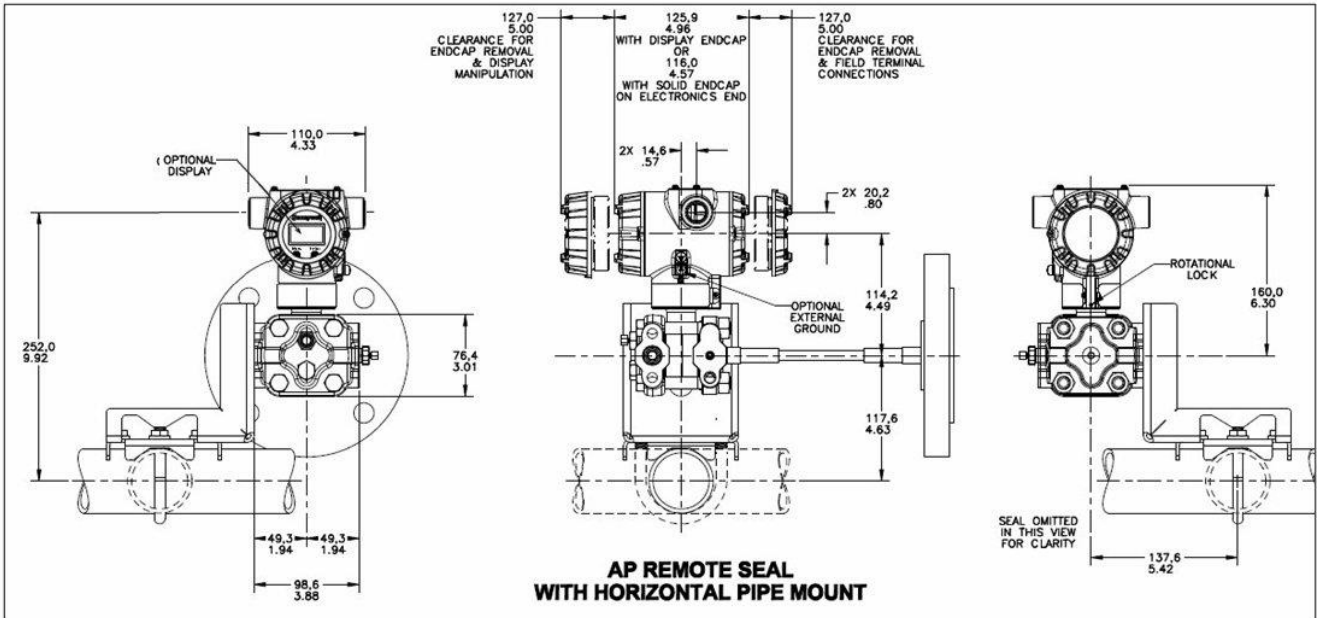
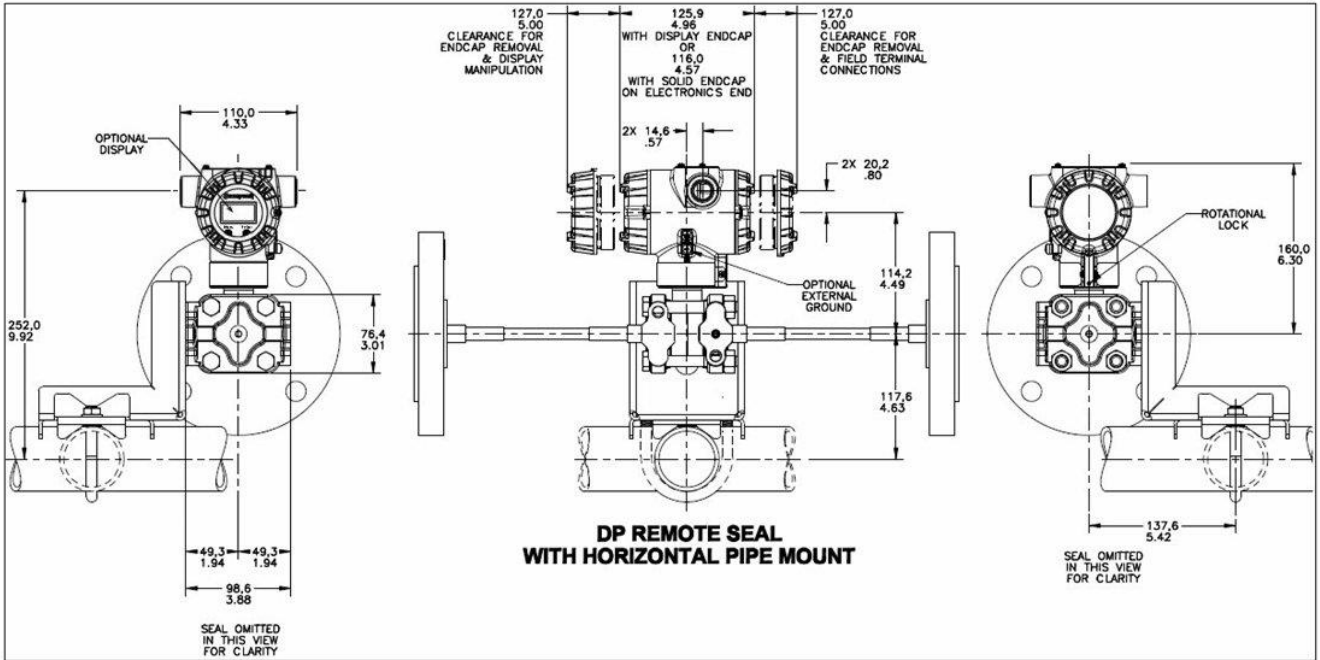



Reference Dimensions Horizontal Mounting (cont'd)

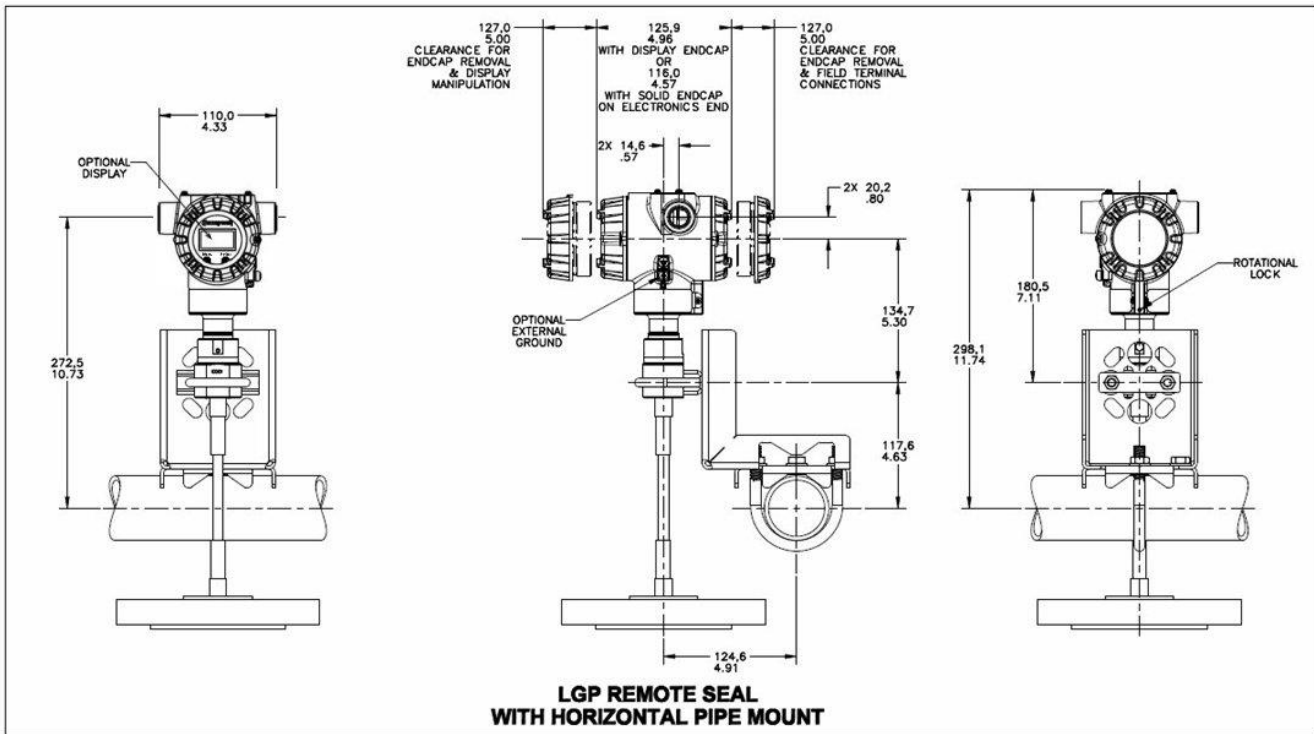
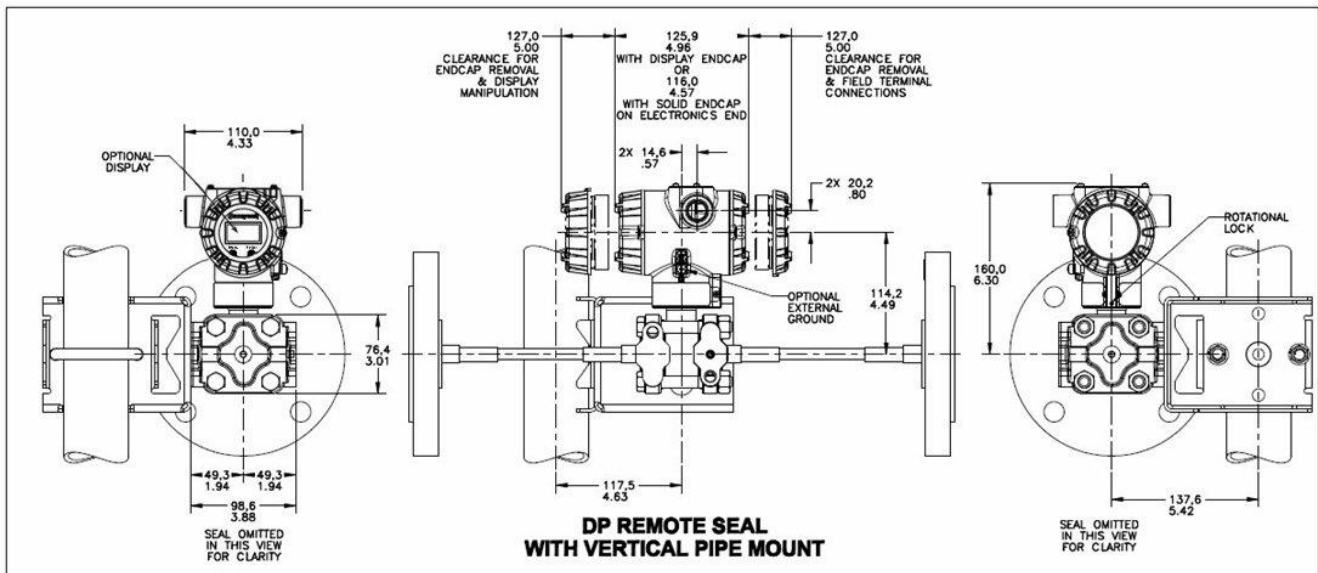

Figure 6 - Approximate Horizontal Mounting Dimensions for Remote Seal Transmitter

Reference Dimensions Vertical Mounting



Reference Dimensions Vertical Mounting (cont'd)

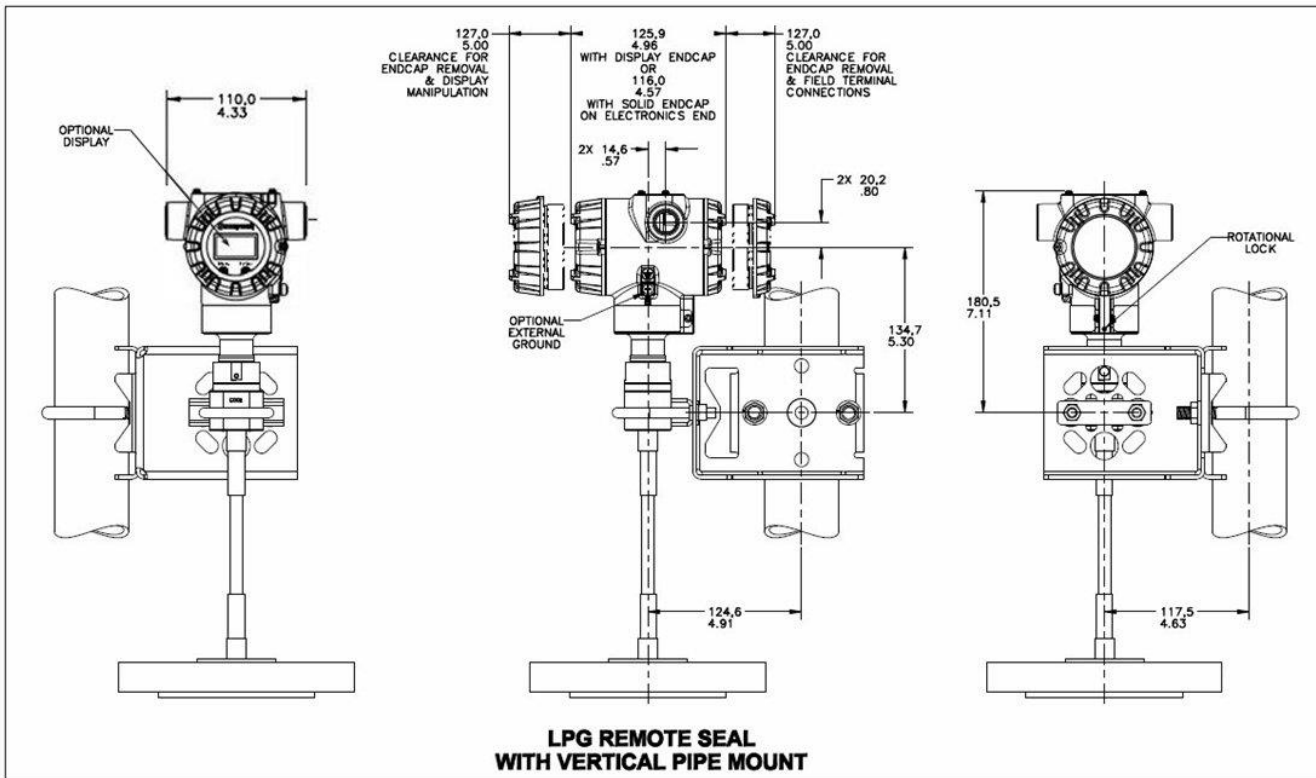
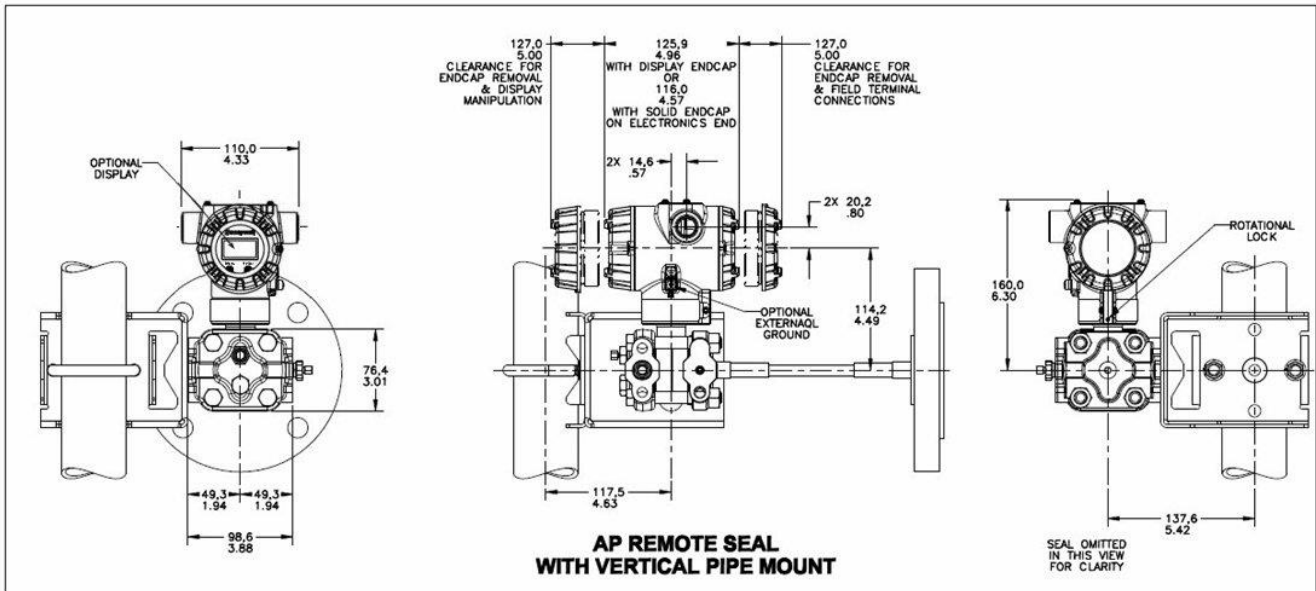
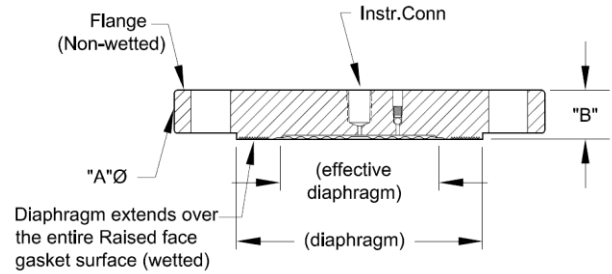

Figure 7 — Approximate vertical mounting dimensions for Remote Seal Transmitter

**Reference Dimensions (cont'd)**

**Flush Flanged Seal Dimensions**

Type	ANSI/DIN Rating	Flange Material	Wetted Materials		Construction See figure	Dimensions	
			Diaphragm	Body		A	B
Flush Flanged Seal	3" Class 150#	CS	SS	SS	D	7.5	1.37
			Hastelloy C	SS	C		
			Hastelloy C	Hastelloy C	D		
			Monel	Monel	D		
			Tantalum	SS	C		
			SS	N/A	B		
	3" Class 300#	SS	Hastelloy C	SS	A	7.50	0.94
			Hastelloy C	Hastelloy C	D		
			Monel	Monel	D		
			Tantalum	SS	C		
			SS	N/A	B		
			Hastelloy C	SS	A		
	3" Class 600#	CS	Hastelloy C	SS	C	8.25	1.56
			Hastelloy C	Hastelloy C	D		
			Monel	Monel	D		
			Tantalum	SS	C		
			SS	N/A	B		
			Hastelloy C	SS	A		
	3" Class 800#	SS	Hastelloy C	Hastelloy C	D	8.25	1.5
			Monel	Monel	D		
			Tantalum	SS	C		
			SS	N/A	B		
			Hastelloy C	SS	A		
			Hastelloy C	Hastelloy C	D		
DN80-PN40	CS	Hastelloy C	SS	C	7.87	1.32	
		Hastelloy C	Hastelloy C	D			
		Monel	Monel	D			
		Tantalum	SS	C			
		SS	N/A	B			
		Hastelloy C	SS	A			
DN80-PN40	SS	Hastelloy C	Hastelloy C	D	7.87	0.94	
		Monel	Monel	D			
		Tantalum	SS	C			
		SS	N/A	B			
		Hastelloy C	SS	A			
		Hastelloy C	Hastelloy C	D			



**Configuration "HS"**

**Figure A**

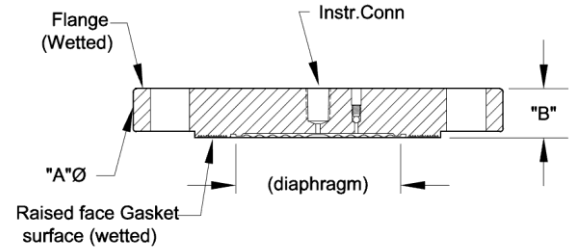

**Configuration "HT"**

**Figure B**

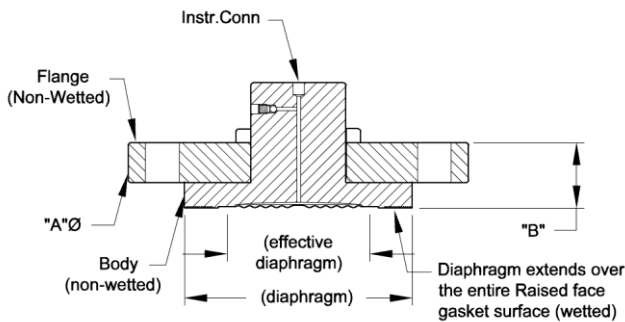

**Configuration "IS"**

**Figure C**

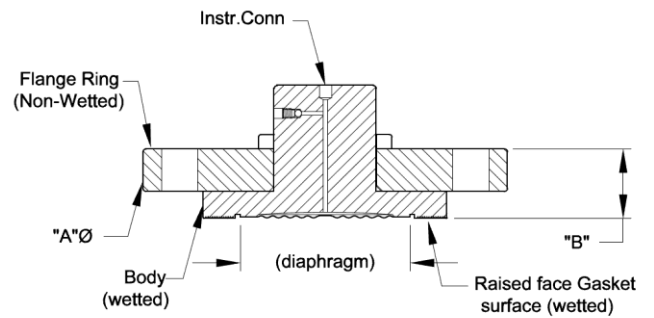

**Configuration "IT"**

**Figure D**

**Figure 8 - Seal Dimensions (Flush Flanged)**

**Reference Dimensions (cont'd) Flush Flanged Seal with Lower**

Type	ANSI/DIN Rating	Size	Dimension	2.4" Diaph. Dia. (in.)	2.9" Diaph. Dia. (in.)	4.1" Diaph. Dia. (in.)
Flush Flanged Seal with Lower	Class 150#	1/2"	A	3.50	4.00	5.25
			B0	1.72	1.72	1.84
			B1	1.72	1.72	1.84
			B2	2.22	2.22	2.34
		1"	A	4.25	4.00	5.25
			B0	1.12	1.72	1.84
			B1	1.62	1.72	1.84
			B2	1.98	1.72	2.34
		1-1/2"	A	5.00	5.00	5.25
			B0	2.50	2.50	1.78
			B1	3.00	3.00	2.12
			B2	3.50	3.40	2.12
	2"	A	6.00	6.00	6.00	
		B0	2.50	2.50	2.12	
		B1	3.00	3.00	2.12	
		B2	3.50	3.40	2.12	
	3"	A	7.50	7.50	7.50	
		B0	2.58	2.88	2.80	
		B1	2.88	2.88	3.00	
		B2	3.50	3.40	3.40	
	Class 300#	1"	A	4.88	4.00	5.25
			B0	2.50	1.72	1.88
			B1	3.00	1.72	2.12
			B2	3.50	2.22	2.12
1-1/2"		A	6.12	6.12	5.25	
		B0	2.50	2.50	2.12	
		B1	3.00	3.00	2.12	
		B2	3.50	3.40	2.12	
2"		A	6.50	6.50	6.50	
		B0	2.50	2.50	2.70	
		B1	3.00	3.00	3.00	
		B2	3.50	3.40	3.50	
3"	A	8.25	8.25	8.25		
	B0	3.48	3.48	3.20		
	B1	3.48	3.48	3.60		
	B2	4.10	4.00	4.00		
Class 600#	1"	A	4.88	4.50	5.25	
		B0	2.50	2.15	2.26	
		B1	3.00	2.15	2.26	
		B2	3.50	2.40	2.50	
	1-1/2"	A	6.12	6.12	5.25	
		B0	2.50	1.53	2.50	
		B1	3.00	2.09	3.00	
		B2	3.50	2.49	3.50	
	2"	A	6.50	6.50	6.50	
		B0	3.10	3.10	3.30	
		B1	3.60	3.60	3.60	
		B2	4.10	4.00	4.10	
3"	A	8.25	8.25	8.25		
	B0	3.48	3.48	3.20		
	B1	3.48	3.48	3.60		
	B2	4.10	4.00	4.00		

B0 Without Flush  
 B1 B Dimension with 1/4 NPT Flushing Connection  
 B2 B dimension with 1/2 NPT Flushing Connection

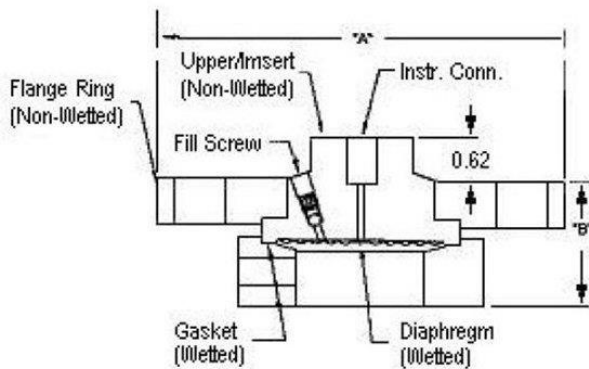

**Flush Flanged Seal with Lower**

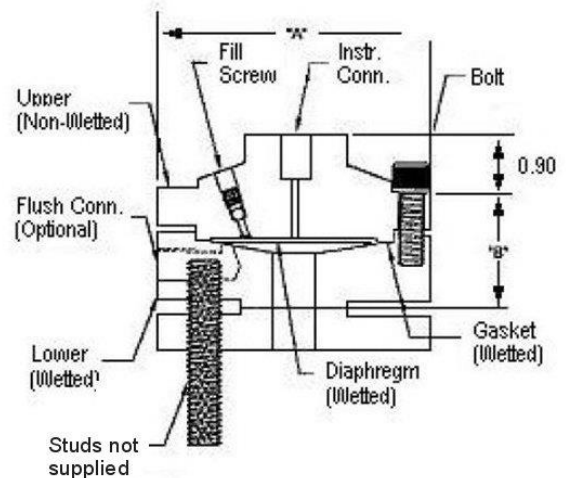

**Flush Flanged Seal with Lower**

Note: 0.90 dimension is 0.70 for 4.1" Dia Diaphragm

**Figure 9 - Seal Dimension (Flush Flanged)**

**Reference Dimensions (cont'd)**

**Flanged Seal with Extended Diaphragm**

Type	ANSI/DIN Rating	Dimension	2.8" Diaphragm Dia. (in.)	3.5" Diaphragm Dia. (in.)
Flanged Seal with Extended Diaphragm	3" Class 150#	A	7.50	-
		B	0.94	-
		C	2.80	-
	3" Class 300#	A	8.25	-
		B	1.12	-
		C	2.80	-
	DIN DN80-PN40	A	7.87	-
		B	0.94	-
		C	2.80	-
	4" Class 150#	A	-	9.00
		B	-	0.94
		C	-	3.70
4" Class 300#	A	-	10.00	
	B	-	1.25	
	C	-	3.70	
DIN DN100-PN40	A	-	9.25	
	B	-	0.94	
	C	-	3.70	

Designed to meet with schedule 40 pipe

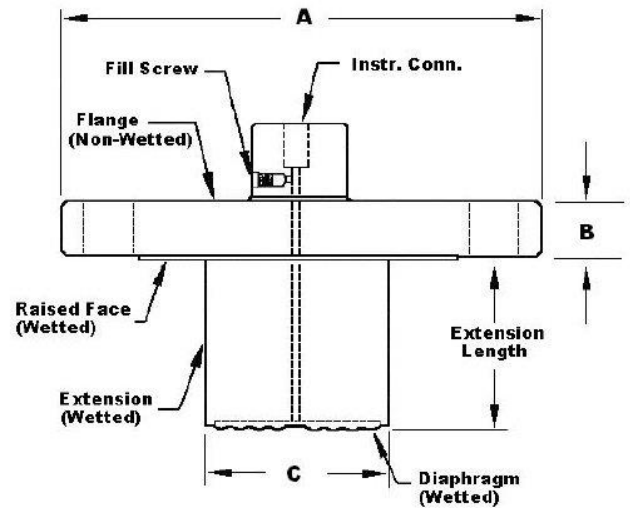

**Figure 10 — Seal Dimensions (Extended Diaphragms)**

**Pancake Seal**

Type	ANSI/DIN	Dimension	3.5" Diaph. (in.)
Pancake Seal	Class 150#, 300#, 600# DN80-PN40	A	5.00
		B	1.08

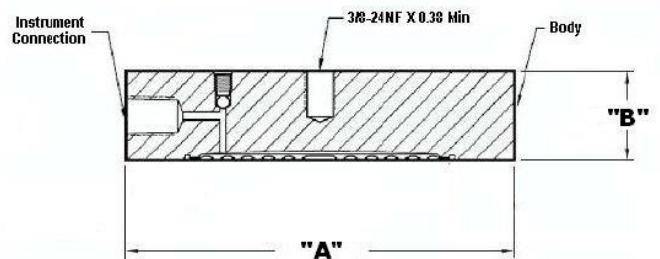

**Figure 11 — Seal Dimensions (Pancake)**

**Seal with Threaded Process Connection**

Type	Size	Dimension	2.4" Diaphragm Dia. (in.)	2.9" Diaphragm Dia. (in.)	4.1" Diaphragm Dia. (in.)
Threaded Process Conn. Seal	1/4" or 1/2"	A	3.50	4.00	5.25
		B0	1.66	1.66	1.79
		B1	1.66	1.66	1.79
		B2	2.18	2.18	2.14
	3/4" or 1"	A	3.50	4.00	5.25
		B0	1.66	1.66	1.79
		B1	1.66	1.66	1.79
		B2	8.25	2.18	2.14

- B0 Without Flush
- B1 B Dimension with 1/4 NPT Flushing Connection
- B2 B dimension with 1/2 NPT Flushing Connection

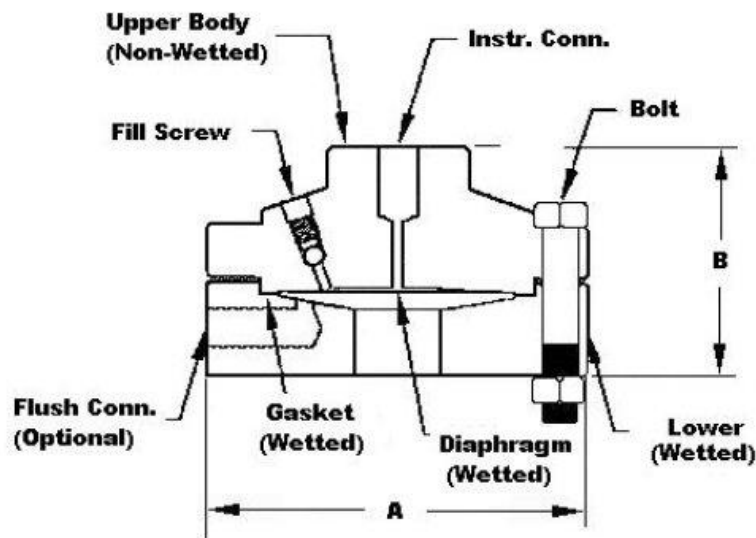

Figure 12— Seal Dimensions (Threaded Process Connection Seals)

**Calibration Ring**

Type	Size	Rating	Dimension	1/4 NPT	1/2 NPT
Calibration Ring	3"	150# / 800#	A	5.00	5.00
			B	1.00	1.50
			C	3.00	3.00

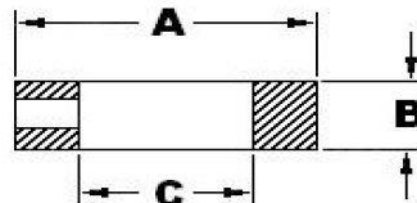

Figure 13— Calibration Ring

## Communications Protocols & Diagnostics

### HART Protocol

#### Version:

HART 7

#### Standard Diagnostics

ST 700 top level diagnostics are reported as either critical or non-critical and readable via the DD/DTM tools or integral display as shown below.

#### Critical Diagnostics

HART DD/DTM Tools	Standard Display
Electronic Module DAC Failure	Fault Comm EI
Meter Body NVM Corrupt	Fault Mtrbody
Config. Data Corrupt	Fault Comm EI
Electronic Module Diag Failure	Fault Comm EI
Meter Body Critical Failure	Fault Mtrbody
Sensor Comms Timeout	Fault Mbd Com

#### Non-Critical Diagnostics

HART DD/DTM Tools
Display Failure
Electronic Module Comm Failure
Meter Body Excess Correct
Sensor Over Temperature
Fixed Current Mode
PV Out of Range
No Factory Calibration
LRV Set Error – Zero Config. Button
URV Set Error – Zero Config. Button
AO Out of Range
Loop Current Noise
Meter Body Unreliable Comm
No DAC Calibration
Sensor Supply Voltage Low

Refer to ST 700 manuals for additional level diagnostic information.

**Hazardous Areal Certifications:**

MSG CODE	AGENCY	TYPE OF PROTECTION	COMM. OPTION	ELECTRICAL PARAMETERS	AMBIENT TEMP (Ta)
A	FM Approvals™ USA	<b>Explosionproof:</b> Class I, Division 1, Groups A, B, C, D; Dust Ignition Proof: Class II, III, Division 1, Groups E, F, G; T6..T5 Class I, Zone 0/1, AEx db IIC T6..T5 Ga/Gb Class II, Zone 21, AEx tb IIIC T95° Db	All	Note 1	T5: -50 °C to 85°C T6: -50 °C to 65°C
		<b>Intrinsically Safe:</b> Class I, II, III, Division 1, Groups A, B, C, D, E, F, G: T4 Class I, Zone 0, AEx ia IIC T4 Ga FISCO Field Device (Only for FF Option) Ex ia IIC T4 Ga; Ex ic IIC T4 Gc	4-20 mA / DE/ HART	Note 2a	-50 °C to 70°C
		<b>Nonincendive:</b> Class I, Division 2, Groups A, B, C, D locations, T4 Class I, Zone 2, AEx nA IIC T4 Gc	Foundation Fieldbus	Note 2b	-50 °C to 70°C
		<b>Enclosure:</b> Type 4X/ IP66/ IP67	4-20 mA / DE/ HART/ Foundation Fieldbus	Note 1	-50 °C to 85°C
		<b>STANDARDS:</b> FM Class 3600:2011; FM Class 3610: 2010; FM Class 3611: 2004; FM Class 3615: 2006; FM Class 3616: 2011; FM Class 3810: 2005; ANSI/ISA 60079-0: 2013; ANSI/UL 60079-1: 2015; ANSI/UL 60079-11: 2014; ANSI/ISA 60079-15: 2012; ANSI/UL 60079-26: 2017; ANSI/UL 60079-31: 2015; ANSI/NEMA 250: 2003; ANSI/ IEC 60529: 2004	All	All	-
B	Canadian Standards Association (CSA) USA and Canada	<b>Explosion Proof:</b> Class I, Division 1, Groups A, B, C, D; Class II, Division 1, Groups E, F, G; Class III, Division 1, T6..T5 Class I Zone 1 AEx db IIC T6..T5 Ga/Gb Ex db IIC T6..T5 Ga/Gb Zone 22 AEx tb IIIC T95° Db Ex tb IIIC T95° Db	All	Note 1	T5: -50°C TO 85°C T6: -50°C TO 65°C
		<b>Intrinsically Safe:</b> Class I, II, III, Division 1, Groups A, B, C, D; Class II, Division 1, Groups E, F, G; Class III, Division 1, T4 Class I Zone 0, AEx ia IIC T4 Ga Class I Zone 2, AEx ic IIC T4 Gc Ex ia IIC T4 Ga Ex ic IIC T4 Gc FISCO Field Device (Only for FF Option) Ex ia IIC T4 Ga; Ex ic IIC T4 Gc	4-20 mA / DE/ HART	Note 2	-50°C TO 70°C
		<b>Nonincendive:</b> Class I, Division 2, Groups A, B, C, D; Class II, Division 2, Groups F, G; Class III, Division 2, T4 Class I Zone 2 AEx nA IIC T4 Gc Ex nA IIC T4 Gc	Foundation Fieldbus	Note 2	-50°C TO 70°C
		<b>Enclosure:</b> Type 4X/ IP66/ IP67	4-20 mA / DE/ HART/ Foundation Fieldbus	Note 1	-50°C to 85°C
			All	All	-



MSG CODE	AGENCY	TYPE OF PROTECTION	COMM. OPTION	ELECTRICAL PARAMETERS	AMBIENT TEMP (Ta)
		<b>STANDARDS:</b> CSA C22.2 No. 0-10; CSA C22.2 No. 94-M91; CSA C22.2 No. 25-1966; CSA C22.2 No. 30-M1986; CSA C22.2 No. 142-M1987; CSA C22.2 No. 157-92; CSA C22.2 No. 213-M1987; CSA-C22.2 No. 60529:05; CSA-C22.2 No. 60079-0:11; CSA-C22.2 No. 60079-1:11; CSA-C22.2 No. 60079-11:11; CSA-C22.2 No. 60079-15:12; CSA-C22.2 No. 60079-31:12; ISA 12.12.01-2010; ISA 60079-0: 2009; ISA 60079-11: 2011; ISA 60079-15: 2009; ISA 60079-26: 2008; ISA-60079-27:2007 (12.02.04)-2006 (R2011); UL 913 Ed. 6; UL 916:1998; ANSI/ISA-12.27.01-2011			
C	ATEX	<b>Flameproof: SIRA 12ATEX2233X</b> II 1/2 G Ex db IIC T6..T5 Ga/Gb II 2 D Ex tb IIIC T95°C...T120°C Db	All	Note 1	T5: -50°C TO 85°C T6: -50°C TO 65°C
		<b>Intrinsically Safe: SIRA 12ATEX2233X</b> II 1 G Ex ia IIC T4 Ga FISCO Field Device (Only for FF Option) II 1 G Ex ia IIC T4 Ga	4-20 mA / DE/ HART	Note 2	-50°C TO 70°C
			Foundation Fieldbus	Note 2	-50°C TO 70°C
		<b>Zone 2, Increase Safety: SIRA 12ATEX4234X</b> II 3 G Ex ec IIC T4 Gc	4-20 mA / DE/ HART/	Note 1	-50°C TO 85°C
		<b>Zone 2, Intrinsically Safe: SIRA 12ATEX4234X</b> II 3 G Ex ic IIC T4 Gc FISCO Field Device (Only for FF Option) II 3 G Ex ic IIC T4 Gc	4-20 mA / DE/ HART/ Foundation Fieldbus	Note 2	-50°C TO 85°C
		<b>Enclosure:</b> IP66/ IP67	All	All	-
<b>STANDARDS:</b> EN 60079-0: 2012/A11: 2013; EN 60079-1: 2014; EN 60079-7: 2015; EN 60079-11: 2012; EN 60079-26: 2015; EN 60079-31: 2009					
D	IECEX World	<b>Flameproof: IECEx SIR 12.0100X</b> Ex db IIC T6..T5 Ga/Gb Ex tb IIIC T95°C...T120°C Db	All	Note 1	T5: -50°C TO 85°C T6: -50°C TO 65°C
		<b>Intrinsically Safe: IECEx SIR 12.0100X</b> Ex ia IIC T4 Ga FISCO Field Device (Only for FF Option) Ex ia IIC T4 Ga; Ex ic IIC T4 Gc	4-20 mA / DE/ HART	Note 2	-50°C TO 70°C
			Foundation Fieldbus	Note 2	-50°C TO 70°C
		<b>Zone 2, Increase Safety: IECEx SIR 12.0100X</b> Ex ec IIC T4 Gc	4-20 mA / DE/ HART/ Foundation Fieldbus	Note 1	-50°C TO 85°C
		<b>Zone 2, Intrinsically Safe: IECEx SIR 12.0100X</b> Ex ic IIC T4 Gc FISCO Field Device (Only for FF Option) Ex ic IIC T4 Gc	4-20 mA / DE/ HART/ Foundation Fieldbus	Note 2	-50°C TO 85°C
		<b>Enclosure:</b> IP66/ IP67	All	All	-
<b>STANDARDS:</b> IEC 60079-0: 2011; IEC 60079-1: 2014; IEC 60079-7: 2017; IEC 60079-11: 2011; IEC 60079-26: 2014; IEC 60079-31: 2013					

E	SAEx South Africa	<b>Flameproof :</b> Ex d IIC T6...T5 Ga/Gb Ex tb IIIC T95°C...T120°C Db	All	Note 1	T5: -50°C TO 85°C T6: -50°C TO 65°C
		<b>Intrinsically Safe:</b> Ex ia IIC Ga T4 FISCO Field Device (Only for FF Option) Ex ia IIC T4 Ga; Ex ic IIC T4 Gc	4-20 mA / DE/ HART	Note 2	-50°C TO 70°C
			Foundation Fieldbus	Note 2	-50°C TO 70°C
		<b>Zone 2, Increase Safety:</b> II 3 G Ex ec IIC T4 Gc	4-20 mA / DE/ HART/ Foundation Fieldbus	Note 1	-50°C TO 85°C
		<b>Zone 2, Intrinsically Safe:</b> Ex ic IIC T4 Gc FISCO Field Device (Only for FF Option) Ex ic IIC T4 Gc	4-20 mA / DE/ HART/ Foundation Fieldbus	Note 2	-50°C TO 85°C
<b>Enclosure:</b> IP66/ IP67	All	All	-		
F	INMETRO Brazil	<b>Flameproof:</b> Ex db IIC T6..T5 Ga/Gb Ex tb IIIC T95°C...T120°C Db	All	Note 1	T5: -50°C TO 85°C T6: -50°C TO 65°C
		<b>Intrinsically Safe:</b> Ex ia IIC T4 Ga  FISCO Field Device (Only for FF Option) Ex ia IIC T4 Ga; Ex ic IIC T4 Gc	4-20 mA / DE/ HART	Note 2a	-50°C TO 70°C
			Foundation Fieldbus	Note 2b	-50°C TO 70°C
		<b>Zone 2, Increase Safety:</b> II 3 G Ex ec IIC T4 Gc	4-20 mA / DE/ HART/ Foundation Fieldbus	Note 1	-50°C TO 85°C
		<b>Zone 2, Intrinsically Safe:</b> Ex ic IIC T4 Gc FISCO Field Device (Only for FF Option) Ex ic IIC T4 Gc	4-20 mA / DE/ HART/ Foundation Fieldbus	Note 2	-50°C TO 85°C
<b>Enclosure :</b> IP 66/67	All	All	-		
G	NEPSI CHINA	<b>Flameproof:</b> Ex db IIC T6..T5 Ga/Gb Ex tb IIIC T 95°C Db	All	Note 1	T5: -50°C TO 85°C T6: -50°C TO 65°C
		<b>Intrinsically Safe:</b> Ex ia IIC T4 Ga FISCO Field Device (Only for FF Option) Ex ia IIC T4 Ga; Ex ic IIC T4 Gc	4-20 mA / DE/ HART	Note 2	-50°C TO 70°C
			Foundation Fieldbus	Note 2	-50°C TO 70°C
		<b>Zone 2, Increase Safety:</b> II 3 G Ex ec IIC T4 Gc	4-20 mA / DE/ HART/ Foundation Fieldbus	Note 1	-50°C TO 85°C
		<b>Zone 2, Intrinsically Safe:</b> Ex ic IIC T4 Gc FISCO Field Device (Only for FF Option) Ex ic IIC T4 Gc	4-20 mA / DE/ HART/ Foundation Fieldbus	Note 2	-50°C TO 85°C
<b>Enclosure :</b> IP 66/67	All	All	-		

I	EAC Russia, Belarus and Kazakhstan	<b>Flameproof:</b> Ga/Gb Ex d IIC T6..T5 Ex tb IIIC Db T 85°C	All	Note 1	T5: -50°C TO 85°C T6: -50°C TO 65°C
		<b>Intrinsically Safe:</b> Ga Ex ia IIC T4 X FISCO Field Device (Only for FF Option) Ga Ex ia IIC T4 X	4-20 mA / DE/ HART	Note 2	-50°C TO 70°C
			Foundation Fieldbus	Note 2	-50°C TO 70°C
		<b>Zone 2, Non Sparking:</b> 2 Ex nA IIC T4 Gc X	4-20 mA / DE/ HART/ Foundation Fieldbus	Note 1	-50°C TO 85°C
		<b>Zone 2, Intrinsically Safe:</b> Ga Ex ic IIC T4 X FISCO Field Device (Only for FF Option) 2 Ex ic IIC T4 Gc X	4-20 mA / DE/ HART/ Foundation Fieldbus	Note 2	-50°C TO 85°C
<b>Enclosure :</b> IP 66/67		All	All		
J	CCoE INDIA	<b>Flameproof:</b> Ex d IIC T6..T5 Ga/Gb	All	Note 1	T5: -50°C TO 85°C T6: -50°C TO 65°C
		<b>Intrinsically Safe:</b> Ex ia IIC T4 Ga FISCO Field Device (Only for FF Option) Ex ia IIC T4 Ga; Ex ic IIC T4 Gc	4-20 mA / DE/ HART	Note 2	-50°C TO 70°C
			Foundation Fieldbus	Note 2	-50°C TO 70°C
		<b>Non Sparking</b> Ex nA IIC T4 Gc	4-20 mA / DE/ HART/ Foundation Fieldbus	Note 1	-50°C TO 85°C
<b>Enclosure:</b> IP66/ IP67		All	All	-	
K	UATR UKRAINE	<b>Flameproof:</b> II 1/2 G Ex db IIC T6..T5 Ga/Gb II 2 D Ex tb IIIC T95°C...T120°C Db	All	Note 1	T5: -50°C TO 85°C T6: -50°C TO 65°C
		<b>Intrinsically Safe:</b> II 1 G Ex ia IIC T4 Ga FISCO Field Device (Only for FF Option) II 1 G Ex ia IIC T4 Ga	4-20 mA / DE/ HART	Note 2	-50°C TO 70°C
			Foundation Fieldbus	Note 2	-50°C TO 70°C
<b>Enclosure:</b> IP66/ IP67		All	All	-	

## Notes:

- Operating Parameters:  
Voltage = 11 to 42 V DC                      Current = 4-20 mA Normal
- Intrinsically Safe Entity Parameters
  - Analog/ DE/ HART Entity Values:  
Vmax = Ui = 30V                      Imax= Ii= 105mA                      Ci = 4.2nF                      Li = 984 uH                      Pi = 0.9W

Transmitter with Terminal Block Revision E or Later

$V_{max} = U_i = 30V$

$I_{max} = I_i = 225mA$

$C_i = 4.2nF$

$L_i = 0$

$P_i = 0.9W$

Note : Transmitter with Terminal Block Revision E or later

The revision is on the label that is on the module. There will be two lines of text on the label:

- First is the Module Part #: 50049839-001 or 50049839-002
- Second line has the supplier information, along with the REVISION:  
XXXXXXX-EXXXX, THE "X" is production related, THE POSITION of the "E" IS THE REVISION.

## Other Certification Options

### SIL

<b>SIL 2/3 Certification</b>	IEC 61508 SIL 2 for non-redundant use and SIL 3 for redundant use according to EXIDA and TÜV Nord Sys Tec GmbH & Co. KG under the following standards: IEC61508-1: 2010; IEC 61508-2: 2010; IEC61508-3: 2010.
------------------------------	---

### Materials

- NACE MR0175, MR0103, ISO15156

**Application Data****Liquid Level: Closed Tank**

Determine the minimum and maximum pressure differentials to be measured (Figure 14)

$$\begin{aligned} P_{\text{Min}} &= (SG_p \times a) - (SG_f \times d) \\ &= \text{LRV when HP at bottom of tank} \\ &= -\text{URV when LP at bottom of tank} \end{aligned}$$

$$\begin{aligned} P_{\text{Max}} &= (SG_p \times b) - (SG_f \times d) \\ &= \text{URV when HP at bottom of tank} \\ &= -\text{LRV when LP at bottom of tank} \end{aligned}$$

Where:

minimum level at 4mA  
maximum level at 20 mA

a = distance between bottom tap and minimum level

b = distance between bottom tap and maximum level

d = distance between taps

$SG_f$  = Specific Gravity of capillary fill fluid (See page 6 "Material Spec" for values.)

$SG_p$  = Specific Gravity of process fluid

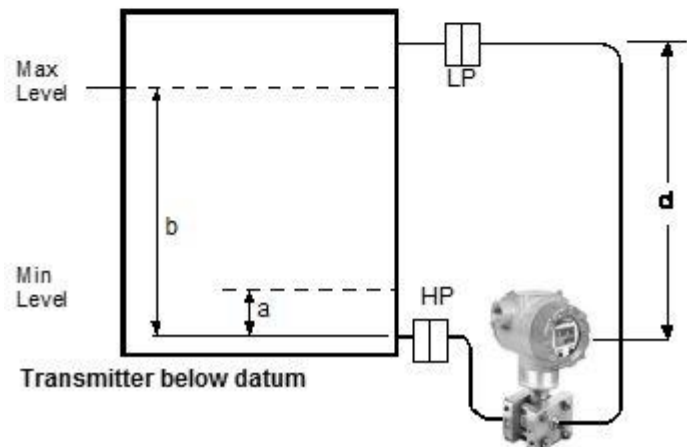
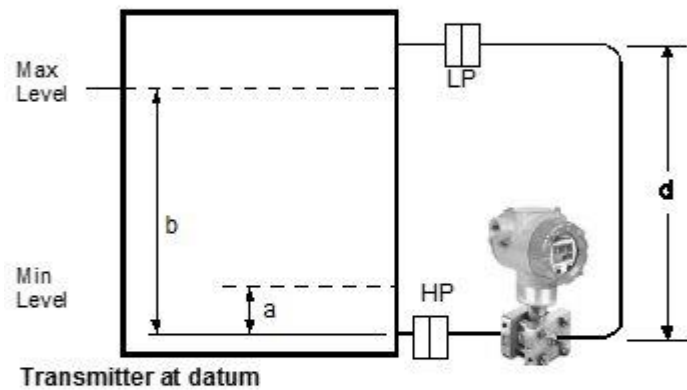
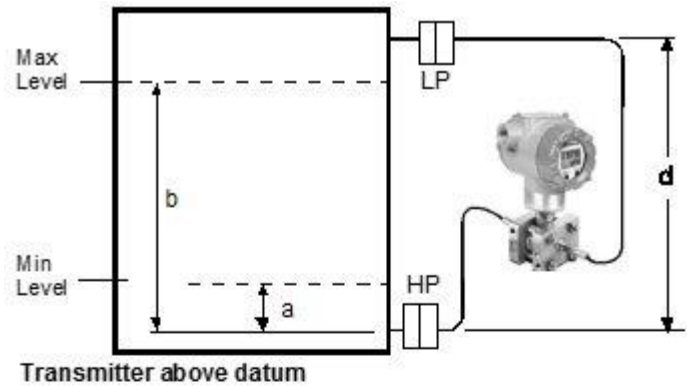

Figure 14—Closed tank liquid level measurement distance

### Application Data (Cont'd)

#### Density or Interface\*

Calculate the minimum and maximum pressure differentials to be measured. (Figure 15)

$$P_{\min} = (SG_{\min} - SG_f) \times (d);$$

minimum density, 4mA output

$$P_{\max} = (SG_{\max} - SG_f) \times (d);$$

maximum density, 20mA output

Where:

d = distance between the taps

SG<sub>max</sub> = maximum Specific Gravity

SG<sub>min</sub> = minimum Specific Gravity

SG<sub>f</sub> = Specific Gravity of capillary fill fluid (See page 6 "Material Specifications" for values.)

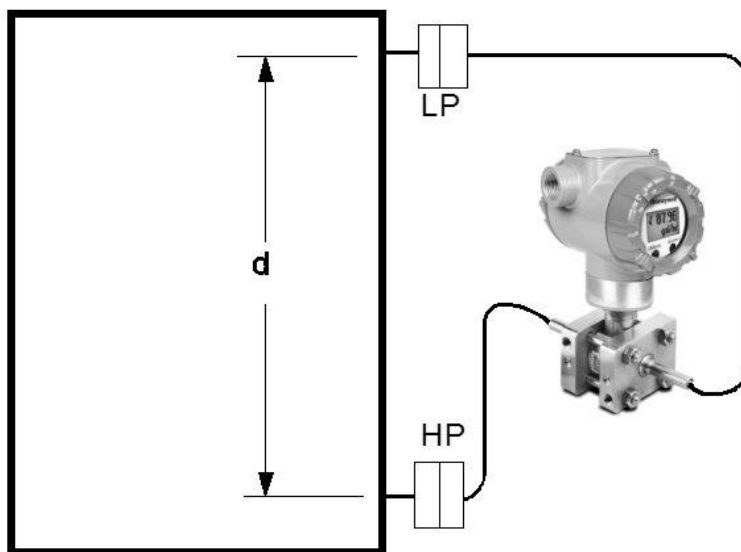

Figure 15- Density, direct acting transmitter configuration

### Seal Configurations

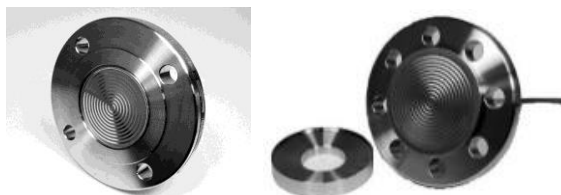

Figure 16—Flush Flange Seals and with Left Lower

Flush Flange Seals can be used with differential, gauge and absolute pressure transmitters and are available with 3" ANSI Class 150, ANSI Class 300 and DIN DN80-PN40 process connections. Flush flange seals can also be provided with Lowers. Lowers are essentially calibration rings, which allow flushing connections if needed.



Figure

Pancake Seals

17—

Pancake Seals can be used with differential, gauge and absolute pressure transmitters and are available with 3" ANSI Class 150, 300 and 600 process connections

## Seal Configurations (cont'd)



**Figure 18 — Flange Seal with Extended Diaphragm**

Flange Seal with Extended Diaphragm can be used with differential, gauge and absolute pressure transmitters and are available with 3" and 4" ANSI Class 150, ANSI Class 300, DIN DN80-PN40 and DIN DN100-PN40 process connections. 2", 4" and 6" extension lengths are available



**Figure 19— Seals with Threaded Process Connections**

Seals with Threaded Process Connections can be used with differential, gauge and absolute pressure transmitters and are available with 1/2", 3/4" and 1" NPT Female process connections.



**Figure 20 — Calibration Rings**

Calibration Rings are available with Flush Flange Seals and Pancake Seals. Flushing ports (1/4" or 1/2") are available with calibration rings.



**Figure 21 — Stainless Steel Armor and PVC Coated Stainless Steel Armor Capillaries**

Stainless Steel Armor and PVC Coated Stainless Steel Armor Capillaries are available with Honeywell Remote Seal Solutions.



**Figure 22 — 2" Stainless Steel Nipples**

2" Stainless Steel Nipples are available for Close-Coupled remote seal solutions



**Figure 23 — Welded Meter Body for All-Welded Remote Seal Solution**

Welded Meter Body for All-Welded Remote Seal Solution. The welded ST 700 meter body is an important part of an All-Welded Remote Seal Solution, which is commonly used in Vacuum applications.

**Model Selection Guide**

Model Selection Guides are subject to change and are inserted into the specifications as guidance only.

**Model STR700  
(DP, GP) Remote Seals**

Model Selection Guide  
34-ST-16-124 Issue 8

**Instructions**

- Select the desired Key Number. The arrow to the right marks the selection available.
- Make selections from each Table (I, II and IX) using the column below the proper arrow.
- A (●) denotes unrestricted availability. A letter denotes restricted availability.
- Restrictions follow Table IX.

Key Number STR7 \_\_\_ - [ I ] - [ II ] - [ III ] - [ IV ] - [ V ] - [ VI ] - [ VII ] - [ VIII ] + [ IX ]

KEY NUMBER	URL	LRL	Max Span	Min Span	Units	Selection	Availability
Measurement Range Std Accuracy	100 (7)	-100 (-7)	100 (7)	0.9 (0.062)	psi (bar)	STR735D	↓
	500 (35)	-14.7 (-1.0)	500 (35)	5 (0.35)	psi (bar)	STR745G	↓

Note: Remote seal system pressure rating is body rating or seal rating, whichever is less.

TABLE I	Description		Selection	Availability		
Meter Body & Capillaries	a. Number of Seals	1 Remote Seal (High Side)	1 _____	●	●	
		2 Remote Seals	2 _____	●	●	
		1 Remote Seal (Low Side)	3 _____	●	●	
	b. Primary Fill Fluid (Meter body)	Silicone Oil 200	_ 1 _____	●	●	
		Fluorinated Oil CTFE	_ 2 _____	2	2	
	<b>c. Construction Non-Wetted Adapter Head Materials</b>					
	In-Line Gauge	316 SS Bonnet	_ A _____	●	●	
		316 SS Bonnet for Close-Couple	_ B _____	3	3	
	Dual Head DP	316 SS (bolt-on heads)	_ C _____	●	●	
		316 SS for Close-Couple	_ D _____	3	3	
316 SS with all-welded meter body		_ E _____	4	4		
d. Bolts and Nuts for Transmitter Heads	None	_ 0 _____	22	●		
	Carbon Steel Bolts and Nuts	_ C _____	●	●		
	316 SS Bolts and Nuts	_ S _____	●	●		
	A286 SS (NACE) Bolts and 304 SS (NACE) Nuts	_ N _____	●	●		
e. Secondary Fill Fluid (capillary & seal)**	No Fill Fluid	_ 0 _____	5	5		
	Silicone Oil 200	_ 1 _____	●	●		
	Fluorinated Oil CTFE	_ 2 _____	●	●		
	Silicone Oil 704	_ 3 _____	●	●		
	Neobee® M20 <sup>11</sup> Syltherm® 800 <sup>12</sup>	_ 4 _____ _ 5 _____	●	●		
f. Connection of Remote Seal to Meter Body**	No Capillary, No Nipple (Specify for VAM Unit Only)		_ 0 _____	5	5	
	Capillary Length	5 feet 1.5 m	_ A _____	●	●	
		10 feet 3.0 m	_ B _____	●	●	
		15 feet 4.5 m	_ C _____	●	●	
		20 feet 6.1 m	_ D _____	●	●	
		25 feet 7.5 m	_ E _____	●	●	
		35 feet 10.7 m	_ F _____	●	●	
	PVC Coated SS Armor	5 feet 1.5 m	_ G _____	●	●	
		10 feet 3.0 m	_ H _____	●	●	
		15 feet 4.5 m	_ J _____	●	●	
		20 feet 6.1 m	_ K _____	●	●	
		25 feet 7.5 m	_ L _____	●	●	
		35 feet 10.7 m	_ M _____	●	●	
2 inch long SS nipple close-coupled		_ 2 _____	6	6		
g. Seal Option**	None	_ 0 _____	●	●		
	Teflon Coated Seal Diaphragm - only for anti-sticking	_ 4 _____	7	7		

<sup>10</sup> Refer to 34-ST-00-128 for additional options, consult factory

<sup>11</sup> Limited vacuum availability.

<sup>12</sup> Minimum static pressure requirement. No vacuum allowed. See Specifications 34-ST-03-88 Figure 15



In-Line Gauge



Dual Head DP



All welded



STR745G  
STR735D

**Note:** When selecting required seal, you must specify only the 9 selections within the required seal type.

TABLE II		Description			Selection					
Seals	No Seal Attached to Core Transmitter (Specify for VAM Unit Only)			0 0 0 0 0 0 0 0		21	21			
	 Flush Flanged Seal**	Seal Type	Diaphragm Diameter	Flange Size	Flange Pressure Rating <sup>1</sup>	Selection				
						3.5"	3"	ANSI Class 150 ANSI Class 300	AFA _____ AFC _____	• • • •
							80mm	DIN DN80-PN40	AFM _____	• •
		Wetted Material	Diaphragm	Upper Insert	Selection					
					316L SS Hastelloy® C-276 Hastelloy® C-276 Monel 400® Tantalum <sup>5</sup>	316L SS 316L SS Hastelloy® C-276 Monel 400® 316L SS	____ AA ____ ____ AB ____ ____ AC ____ ____ AE ____ ____ AF ____	• • • • • • 8 8 8 8		
			Non-Wetted Material (upper)		CS (Nickel Plated) 316L SS	____ 1 ____ ____ 2 ____	• • • •			
			Seal-Capillary Connection		Center Seal Side Seal	____ 1 ____ ____ 2 ____	• • 9 9			
		Calibration Rings	None 316L SS Hastelloy® C-276 Monel 400®		____ A ____ ____ B ____ ____ C ____ ____ D ____	• • 10 10 10 10 10 10				
			Flushing Connections and Plugs <sup>4</sup> (Metal plug material will be the same as Cal. ring material if metal plug is chosen )	None		____ 0 ____	• •			
		One 1/4" with plastic plug		____ H ____	11 11					
		One 1/4" with metal plug		____ J ____	11 11					
		Two 1/4" with plastic plugs		____ M ____	11 11					
		Two 1/4" with metal plugs		____ N ____	11 11					
		One 1/2" with plastic plug		____ P ____	11 11					
One 1/2" with metal plug		____ Q ____		11 11						
Two 1/2" with plastic plugs		____ R ____	11 11							
Two 1/2" with metal plugs		____ S ____	11 11							

Table II continued next page

<sup>\*\*</sup> Refer to 34-ST-00-128 for additional options, consult factory

<sup>1</sup> Standard facing 125-250 AARH RF (raised face) serrated surface finish.

<sup>4</sup> Plastic Plugs are TEMPORARY ONLY to protect threads and MUST be REMOVED before installation

<sup>5</sup> Tantalum Upper insert has Tantalum wetted parts and 316 SS or CS non-wetted parts

Note: Remote seal system pressure rating is body rating or seal rating, whichever is less.

STR745G  
STR735D

TABLE II		Description				Selection		
Seal Type	Diaphragm Diameter	Flange Size	Flange Pressure Rating <sup>1</sup>	Const. - See Spec. Figure 34-ST-03-104	Construction - See Spec. Figure 34-ST-03-104			
<b>Seals (continued)</b>  Flush Flanged Seal with Lower**	2.4"	1"	ANSI 150 ANSI 300	22 22	BCA _____ BCC _____	• • • •		
		1-1/2"	ANSI 150 ANSI 300	22 22	BGA _____ BGC _____	• • • •		
			2"	ANSI 150 ANSI 300	22 22	BDA _____ BDC _____	• • • •	
		3"	ANSI 150 ANSI 300	22 22	BFA _____ BFC _____	• • • •		
			1/2"	ANSI 150	23	CAA _____	• •	
		2.9"	1"	ANSI 150 ANSI 300	23 23	CCA _____ CCC _____	• • • •	
			1-1/2"	ANSI 150 ANSI 300	22 22	CGA _____ CGC _____	• • • •	
			2"	ANSI 150 ANSI 300	22 22	CDA _____ CDC _____	• • • •	
				1/2"	ANSI 150	22	DAA _____	• •
		4.1"	1"	ANSI 150 ANSI 300	23 23	DCA _____ DCC _____	• • • •	
			1-1/2"	ANSI 150 ANSI 300	23 23	DGA _____ DGC _____	• • • •	
				2"	ANSI 150 ANSI 300	23 22	DDA _____ DDC _____	• • • •
			3"	ANSI 150 ANSI 300	22 22	DFA _____ DFC _____	• • • •	
				<b>Wetted Material</b>		<b>Diaphragm</b>	<b>Lower</b>	<b>Selection</b>
					316L SS	316L SS	--- BA ---	• •
				Hastelloy® C-276	316L SS	--- BB ---	• •	
			Hastelloy® C-276	Hastelloy® C-276	--- BC ---	• •		
			Monel 400®	Monel 400®	--- BE ---	8 8		
			Tantalum	316L SS	--- BF ---	8 8		
			Tantalum	Hastelloy® C-276	--- BG ---	8 8		
			Tantalum	Tantalum Clad	--- BH ---	13 13		
	<b>Non-Wetted Material (upper, upper insert)</b>		<b>Upper</b>	<b>Upper Insert</b>	<b>Selection</b>			
			316L SS	316L SS	----- 4 ---	• •		
			Carbon Steel	316L SS	----- 5 ---	• •		
	<b>Bolts<sup>6</sup></b>		No Selection		----- 0 ---	• •		
	<b>Flushing</b>		None		----- 0 ---	• •		
	<b>Connections and Plugs<sup>4</sup></b> (Metal plug material will be the same as Lower material, if metal plug is chosen - (SS Plug for CS Lower and Tantalum Clad))		One 1/4" with plastic plug		----- H ---	• •		
			One 1/4" with metal plug		----- J ---	• •		
			Two 1/4" with plastic plugs		----- M ---	• •		
			Two 1/4" with metal plugs		----- N ---	• •		
			One 1/2" with plastic plug		----- P ---	• •		
			One 1/2" with metal plug		----- Q ---	• •		
		Two 1/2" with plastic plugs		----- R ---	• •			
		Two 1/2" with metal plugs		----- S ---	• •			
<b>Gasket</b>		Klinger® C-4401 (non-asbestos)		----- K ---	• •			
		Grafoil®		----- G ---	• •			
		Teflon®		----- T ---	• •			
		Gylon® 3510		----- L ---	15 15			

Table II continued next page

\*\* Refer to 34-ST-00-128 for additional options, consult factory

<sup>1</sup> Standard facing 125-250 AARH RF (raised face) serrated surface finish.

<sup>6</sup> Bolt material will be same as Upper Material. However, if Table I bolts/nuts material is NACE, seal bolt material will be 304 SS NACE.

<sup>4</sup> Plastic Plugs are TEMPORARY ONLY to protect threads and MUST be REMOVED before installation

Note: Remote seal system pressure rating is body rating or seal rating, whichever is less.

STR745G  
STR735D

TABLE II	Description							
Seal Type	Diaphragm Diameter	Flange Size	Flange Pressure Rating <sup>1</sup>		Selection			
 Flange Seal with Extended Diaphragm**	2.8"	3" (2.8" OD extension)	ANSI Class 150		EFA _____	•	•	
			ANSI Class 300		EFC _____	•	•	
	DIN DN80-PN40				EFM _____	•	•	
	3.5"	(3.70" OD extension)	ANSI Class 150		FGA _____	•	•	
			ANSI Class 300		FGC _____	•	•	
	DIN DN100-PN40				FGP _____	•	•	
	Wetted Material			Diaphragm	Ext. Tube	Selection		
				316L SS	316L SS	EA _____	•	•
			Hastelloy <sup>®</sup> C-276	316L SS	EB _____	•	•	
			Hastelloy <sup>®</sup> C-276	Hastelloy <sup>®</sup> C-276	EC _____	•	•	
Non-Wetted Material (flange)			CS (Nickel Plated)		7 _____	•	•	
			316L SS		8 _____	•	•	
Bolts			No Selection		0 _____	•	•	
Extension Length			2"		2 _____	•	•	
			4"		4 _____	•	•	
			6"		6 _____	•	•	
No Selection	No Selection	No Selection		0 _____	•	•		

Table II continued below

STR745G  
STR735D

TABLE II	Description							
Seal Type	Diaphragm Diameter	Flange Size	Flange Pressure Rating Dependent on Customer Flange <sup>1</sup>		Selection			
 Pancake Seal	3.5"	3"	ANSI Class 150/300/600		GFA _____	•	•	
			Diaphragm	Body	Selection			
	Wetted Material		316L SS	316L SS	GA _____	•	•	
			Hastelloy <sup>®</sup> C-276	316L SS	GB _____	•	•	
			Hastelloy <sup>®</sup> C-276	Hastelloy <sup>®</sup> C-276	GC _____	•	•	
			Monel 400 <sup>®</sup>	Monel 400 <sup>®</sup>	GE _____	8	8	
			Tantalum	Tantalum <sup>7</sup>	GG _____	8	8	
	Non-Wetted Material			No Selection		0 _____	•	•
	Bolts			No Selection		0 _____	•	•
	Calibration Rings			None		A _____	•	•
				316L SS		B _____	10	10
				Hastelloy <sup>®</sup> C-276		C _____	10	10
				Monel 400 <sup>®</sup>		D _____	10	10
Flushing Connections and Plugs <sup>4</sup> (Metal plug material will be the same as Cal. Ring material, if metal plug is chosen )			None		0 _____	•	•	
		One 1/4" with plastic plug		H _____	11	11		
		One 1/4" with metal plug		J _____	11	11		
		Two 1/4" with plastic plugs		M _____	11	11		
		Two 1/4" with metal plugs		N _____	11	11		
		One 1/2" with plastic plug		P _____	11	11		
		One 1/2" with metal plug		Q _____	11	11		
		Two 1/2" with plastic plugs		R _____	11	11		
		Two 1/2" with metal plugs		S _____	11	11		

Table II continued next page

<sup>\*\*</sup> Refer to 34-ST-00-128 for additional options, consult factory

<sup>1</sup> Standard facing 125-250 AARH RF (raised face) serrated surface finish.

<sup>4</sup> Plastic Plugs are TEMPORARY ONLY to protect threads and MUST be REMOVED before installation

<sup>7</sup> Tantalum Body has Tantalum wetted parts and 316 SS non-wetted parts

Note: Remote seal system pressure rating is body rating or seal rating, whichever is less.

TABLE II	Description						STR745G		STR735D		
	Seal Type	Diaphragm Diameter	Threaded Process Connection Size (NPT Female)	Pressure Rating		Selection					
				CS Bolts	304 SS Bolts						
Seals (continued)		2.4"	1/2 NPT	2,500 psi	1,250 psi	JJG _____	•	•			
			3/4 NPT			JKG _____	•	•			
			1 NPT			JLG _____	•	•			
		2.9"	1/2 NPT	2,500 psi	1,250 psi	KJG _____	•	•			
			3/4 NPT			KKG _____	•	•			
			1 NPT			KLG _____	•	•			
		4.1"	1/2 NPT	1,500 psi	750 psi	LJG _____	•	•			
			3/4 NPT			LKG _____	•	•			
			1 NPT			LLG _____	•	•			
		Wetted Material	Diaphragm		Lower		Selection				
			316L SS	Carbon Steel	_____ JA _____	•	•				
		Non-Wetted Material (upper)	316L SS	316L SS	_____ JB _____	•	•				
			Hastelloy® C-276	316L SS	_____ JC _____	•	•				
			Hastelloy® C-276	Hastelloy® C-276	_____ JD _____	•	•				
			Monel 400®	Monel 400®	_____ JE _____	8	8				
Tantalum	316L SS		_____ JF _____	8	8						
Tantalum	Hastelloy® C-276		_____ JG _____	8	8						
CS (Nickel Plated)			_____ A _____	•	•						
316 Stainless Steel		_____ C _____	17	17							
Bolts <sup>8</sup>		Carbon Steel		_____ C _____	•	•					
		304 SS		_____ D _____	•	•					
Flushing Connections and Plugs <sup>4</sup>		None		_____ 0 _____	•	•					
(Metal plug material will be the same as Lower material, if metal plug is chosen - (SS Plug for CS Lower and Tantalum Clad))		One 1/4" with plastic plug		_____ H _____	•	•					
		One 1/4" with metal plug		_____ J _____	•	•					
		Two 1/4" with plastic plugs		_____ M _____	•	•					
		Two 1/4" with metal plugs		_____ N _____	•	•					
		One 1/2" with plastic plug		_____ P _____	18	18					
		One 1/2" with metal plug		_____ Q _____	18	18					
		Two 1/2" with plastic plugs		_____ R _____	18	18					
Two 1/2" with metal plugs		_____ S _____	18	18							
Gasket	Klinger® C-4401 (non-asbestos)		_____ K _____	•	•						
	Grafoil®		_____ G _____	•	•						
	Teflon®		_____ T _____	•	•						
	Gylon® 3510		_____ L _____	15	15						

Table II continued next page

<sup>4</sup> Plastic Plugs are TEMPORARY ONLY to protect threads and MUST be REMOVED before installation

<sup>8</sup> If Table I Bolts and Nuts material option is NACE, Bolts and Nuts will ship with Alloy Steel NACE and MAWP may change.

Note: Remote seal system pressure rating is body rating or seal rating, whichever is less.

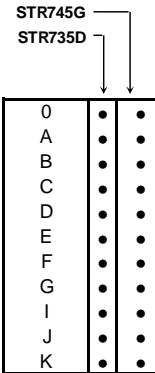

TABLE III	Agency Approvals (see data sheet for Approval Code Details)
Approvals	No Approvals Required FM Explosion proof, Intrinsically Safe, Non-incendive, & Dustproof CSA Explosion proof, Intrinsically Safe, Non-incendive, & Dustproof ATEX Explosion proof, Intrinsically Safe & Non-incendive IECEx Explosion proof, Intrinsically Safe & Non-incendive SAEEx Explosion proof, Intrinsically Safe & Non-incendive INMETRO Explosion proof, Intrinsically Safe & Non-incendive NEPSI Explosion proof, Intrinsically Safe & Non-incendive EAC-Customs Union(Russia,Belarus and Kazakhstan)EX Approval Flameproof,Intrinsically Safe CCoE Explosion proof, Intrinsically Safe & Non-incendive UATR Flameproof, Intrinsically Safe & Dustproof

TABLE IV	TRANSMITTER ELECTRONIC SELECTIONS		
a. Electronic Housing Material & Connection Type	Material	Connection	Lightning Protection
	Polyester Powder Coated Aluminum	1/2 NPT	None
	Polyester Powder Coated Aluminum	M20	None
	Polyester Powder Coated Aluminum	1/2 NPT	Yes
	Polyester Powder Coated Aluminum	M20	Yes
	316 Stainless Steel (Grade CF8M)	1/2 NPT	None
	316 Stainless Steel (Grade CF8M)	M20	None
b. Output/ Protocol	Analog Output		Digital Protocol
	4-20mA dc		HART Protocol
	Indicator	Ext Zero, Span & Config Buttons	Languages
	None	None	None
c. Customer Interface Selections	None	Yes (Zero/Span Only)	None
	Standard (w/internal Zero, Span & Conf Buttons)	None	EN, RU
	Standard (w/internal Zero, Span & Conf Buttons)	Yes	EN, RU

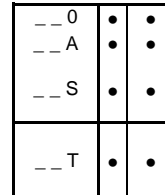
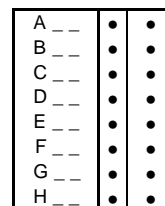

TABLE V	CONFIGURATION SELECTIONS		
a. Application Software	Diagnostics		
	Standard Diagnostics		
b. Output Limit, Failsafe & Write Protect Settings	Write Protect	Fail Mode	High & Low Output Limits <sup>3</sup>
	Disabled	High> 21.0mAdc	Honeywell Std (3.8 - 20.8 mAdc)
	Disabled	Low< 3.6mAdc	Honeywell Std (3.8 - 20.8 mAdc)
	Enabled	High> 21.0mAdc	Honeywell Std (3.8 - 20.8 mAdc)
c. General Configuration	Factory Standard		
	Custom Configuration (Unit Data Required from customer)		

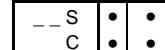
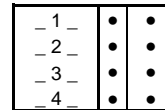
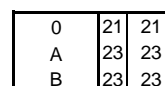

TABLE VI	CALIBRATION & ACCURACY SELECTIONS		
Accuracy and Calibration	Accuracy	Calibrated Range	Calibration Qty
	NA	None	None
	Standard	Factory Std	Single Calibration
	Standard	Custom (Unit Data Required)	Single Calibration



<sup>3</sup> NAMUR Output Limits 3.8 - 20.5mAdc can be configured by the customer or select custom configuration Table Vc

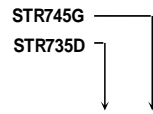

TABLE VII		ACCESSORY SELECTIONS	
	Bracket Type	Material	
a. Mounting Bracket	None	None	
	Angle Bracket	Carbon Steel	
	Angle Bracket	304 SS	
	Angle Bracket	316 SS	
	Marine Approved Bracket	Carbon Steel	
	Marine Approved Bracket (In - Line)	Carbon Steel	
	Marine Approved Bracket	304 SS	
	Marine Approved Bracket (In - Line)	304 SS	
	Flat Bracket	Carbon Steel	
	Flat Bracket	304 SS	
Flat Bracket	316 SS		
b. Customer Tag	Customer Tag Type		
	No customer tag		
	One Wired Stainless Steel Tag (Up to 4 lines 26 char/line) Two Wired Stainless Steel Tag (Up to 4 lines 26 char/line)		
c. Unassembled Conduit Plugs & Adapters	Unassembled Conduit Plugs & Adapters		
	No Conduit Plugs or Adapters Required		
	1/2 NPT Male to 3/4 NPT Female	316 SS Certified Conduit Adapter	
	1/2 NPT	316 SS Certified Conduit Plug	
	M20	316 SS Certified Conduit Plug	

0 ___	•	•
1 ___	•	•
2 ___	•	•
3 ___	•	•
8 ___	y	•
9 ___		•
4 ___	y	•
A ___		•
5 ___	•	•
6 ___	•	•
7 ___	•	•

_ 0 _ _	•	•
_ 1 _ _	•	•
_ 2 _ _	•	•

_ _ A0	•	•
_ _ A2	n	n
_ _ A6	n	n
_ _ A7	m	m

TABLE VIII		OTHER Certifications & Options : (String in sequence comma delimited (XX, XX, XX,...))	
Certifications & Warranty	None - No other options		
	NACE MR0175; MR0103; ISO15156 Process wetted parts only		
	NACE MR0175; MR0103; ISO15156 wetted and non-wetted parts		
	Marine (DNV,ABS,BV,KR,LR)		
	EN10204 Type 3.1 Material Traceability		
	Certificate of Conformance		
	Calibration Test Report & Certificate of Conformance		
	Certificate of Origin		
	FMEDA (SIL 2/3) Certification		
	Over-Pressure Leak Test Certificate (1.5X MAWP)		
Cert Clean for O <sub>2</sub> or CL <sub>2</sub> service per ASTM G93			

00	*	*
FG	•	•
F7	c	c
MT	d	d
FX	•	•
F3	•	•
F1	•	•
F5	•	•
FE	j	j
TP	•	•
OX	e	e

b

b

TABLE IX		Manufacturing Specials	
Factory	Factory Identification		

0 0 0 0	•	•
---------	---	---

**MODEL RESTRICTIONS**

Restriction Letter	Available Only With		Not Available With	
	Table	Selection(s)	Table	Selection(s)
<b>b</b>	Select only one option from this group			
<b>c</b>	ld	___ 0, N, ___		
<b>d</b>	Iva	C, D, G, H __	VIIa	1, 2, 3, 5, 6, 7 ___
<b>e</b>	I	_ 2 _ 2 _		
<b>j</b>	IVb		Vb	_ 1,2 _
<b>m</b>	IVa	B, D, F, H __		
<b>n</b>	IVa	A, C, E, G __		
<b>y</b>			Ic	_ E _ _ _
<b>2</b>	le	----- 0 _ ----- 2 _ ----- 4 _		
<b>3</b>	If	_____ 2 _	Ia	2 _ _ _ _ _
<b>4</b>	I	2 _ 0 _ _		
<b>5</b>	II	000000000	VIII	FG, F7, FX, OX, TP, F1
<b>6</b>	I	_ B, D _ _ _	Ia	2 _ _ _ _ _
<b>7</b>			II	----- AF ----- BF ----- BG ----- BH ----- GG ----- JF ----- JG
<b>8</b>			VIII	FG, F7
<b>9</b>	II	----- AA2 ----- AB2		
<b>10</b>			II	_____ 0
<b>11</b>			II	_____ A _
<b>13</b>	II	_____ 0 _	II VIII	----- T ----- FG, F7
<b>15</b>	II	----- BF ----- BG ----- BH ----- JF ----- JG		
<b>17</b>			II	_____ JA _ _ _
<b>18</b>			II	----- JGG ----- JKG ----- JLG
<b>21</b>	I	_____ 000		
<b>22</b>	Ic	_ E _ _ _		
<b>23</b>			II	000000000

FM Approvals<sup>SM</sup> is a service mark of FM Global  
 Hastelloy<sup>®</sup> is a registered trademark of Haynes International  
 Monel 400<sup>®</sup> is a registered trademark of Special Metals Corporation.  
 HART<sup>®</sup> is a registered trademark of HART Communication Foundation.  
 Teflon<sup>®</sup> is a registered trademark of DuPont.  
 Neobee<sup>®</sup> is a registered trademark of Stepan Company.  
 Syltherm<sup>®</sup> 800 is a Trademark of Dow Corning Corporation  
 Klinger<sup>®</sup> C-4401 is a registered trademark of THERMOSEAL, INC  
 GRAFOIL<sup>®</sup> is a registered trademarks of GrafTech International Holdings Inc  
 Gylon<sup>®</sup> 3510 is registered trademark of Garlock Sealing Technologies

**FIELD INSTALLABLE REPLACEMENT PARTS**

Description
Terminal Strip w/o Lightning Protection Kit for HART Modules
Terminal Strip w/Lightning Protection for HART Modules
HART Electronics Module
HART Electronics Module w/connection for external configuration buttons
Standard Display Module

Kit Number
50129832-501
50129832-502
50129828-501
50129828-502
50126003-501

**PRODUCT MANUALS**

Description
ST 700 Smart Transmitter User Manual - English
ST 700 Smart Transmitter HART Communications Manual - English
ST 700 Smart Transmitter Safety Manual - English

Part Number
34-ST-25-44
34-ST-25-47
34-ST-25-37

All product documentation is available at [www.honeywellprocess.com](http://www.honeywellprocess.com).

---



## Sales and Service

For application assistance, current specifications, ordering, pricing, and name of the nearest Authorized Distributor, contact one of the offices below.

### ASIA PACIFIC

Honeywell Process Solutions,  
Phone: + 800 12026455 or  
+44 (0) 1202645583  
(TAC) [hfs-tac-support@honeywell.com](mailto:hfs-tac-support@honeywell.com)

#### Australia

Honeywell Limited  
Phone: +(61) 7-3846 1255  
FAX: +(61) 7-3840 6481  
Toll Free 1300-36-39-36  
Toll Free Fax:  
1300-36-04-70

#### China – PRC - Shanghai

Honeywell China Inc.  
Phone: (86-21) 5257-4568  
Fax: (86-21) 6237-2826

#### Singapore

Honeywell Pte Ltd.  
Phone: +(65) 6580 3278  
Fax: +(65) 6445-3033

#### South Korea

Honeywell Korea Co Ltd  
Phone: +(822) 799 6114  
Fax: +(822) 792 9015

### EMEA

Honeywell Process Solutions,  
Phone: + 800 12026455 or  
+44 (0) 1202645583

#### Email: (Sales)

[FP-Sales-Apps@Honeywell.com](mailto:FP-Sales-Apps@Honeywell.com)

or

(TAC)

[hfs-tac-support@honeywell.com](mailto:hfs-tac-support@honeywell.com)

#### Web

Knowledge Base search  
engine <http://bit.ly/2N5Vldi>

### AMERICAS

Honeywell Process Solutions,  
Phone: (TAC) (800) 423-9883  
or (215) 641-3610  
(Sales) 1-800-343-0228

#### Email: (Sales)

[FP-Sales-Apps@Honeywell.com](mailto:FP-Sales-Apps@Honeywell.com)

or

(TAC)

[hfs-tac-support@honeywell.com](mailto:hfs-tac-support@honeywell.com)

#### Web

Knowledge Base search  
engine <http://bit.ly/2N5Vldi>

*Specifications are subject to change without notice.*

---

### For more information

To learn more about SmartLine Transmitters,  
visit [www.honeywellprocess.com](http://www.honeywellprocess.com)  
Or contact your Honeywell Account Manager

### Process Solutions

Honeywell  
1250 W Sam Houston Pkwy S  
Houston, TX 77042

Honeywell Control Systems Ltd  
Honeywell House, Skimped Hill Lane  
Bracknell, England, RG12 1EB

Shanghai City Centre, 100 Jungi Road  
Shanghai, China 20061

[www.honeywellprocess.com](http://www.honeywellprocess.com)



34-ST-03-124

January 2022

©2022 Honeywell International Inc.