

ML7430E/ML7435E ELECTRIC LINEAR ACTUATORS FOR MODULATING CONTROL

SPECIFICATION DATA



FEATURES

- 0...10 Vdc / 2...10 Vdc signal input
- Fast run-time
- Low power consumption
- Quick and easy installation
- No separate linkage required
- No calibration
- Force-limiting end switches
- Spring return (ML7435E)
- Manual operator
- Synchronous motor
- Direct / reverse action adjustable
- Maintenance-free

SPECIFICATIONS

Temperature Limits

Ambient operating limits	0...+50 °C at 5 to 95% rh
Ambient storage limits	-40...+70 °C at 5 to 95% rh
Medium valve temperature	max. +130 °C

Signals

Input voltage range	Y = 0...10 Vdc or 2...10 Vdc
Input resistor	R _i = 100 kΩ
Signal source output register	Max. 1 kΩ

Safety

Protection standard	IP54 as per EN60529
Protection class	II as per EN60730-1
Pollution degree	2
Rated impulse voltage	500 V
Flame retardant	V0 as per UL94 (optional with metal cable gland)
Software class	A as per EN 60730-1
Operating mode	See Table 1 on pg. 2

Wiring

Terminals	1.5 mm ²
Cable entry	M20x1.5

Weight

0.37 kg / 0.5 kg

Dimensions

See Fig. 2 and Fig. 3

Material

Cover	ABS-FR
Base	Glass fiber-reinforced plastic

GENERAL

The ML7430E and ML7435E Electric Linear Actuators are designed to provide modulating control in closed control loops together with the small linear valves V5832B/V5833A (DN25...DN40) and V5825B/V5872B for high-differential pressure.

These valve-actuator combinations are suitable especially for integration into compact or conventional stations for direct or indirect district heating connections, air handling units and roof top units for zone control, and domestic hot water applications.

The actuators are microprocessor-controlled for exact positioning. The direction of movement is reversible. The V5825B or V5872B valve and ML7435E actuator combination provides safe close-off function and is approved according to DIN EN 14597.

Table 1. Specifications, by model

OS-number	ML7430E1005	ML7435E1004
supply voltage	24 Vac -15/+20%, 50/60 Hz	
power consumption	4 VA	4 VA
signal input 0(2) Vdc (factory setting)	actuator stem retracts	
signal input 10 Vdc (factory setting)	actuator stem extends	
nominal stroke	6.5 mm	
run-time at 50 Hz	15 s	60 s
nominal stem force	400 N	
spring return time (6.5 mm stroke)	--	max. 20 s
spring return direction	--	actuator stem retracts at power failure
operating mode (as per EN 60730-1, 6.4)	type 1	type 1.AB

OPERATION

General

The drive of a synchronous motor is converted into linear motion of the actuator stem by using a spur gear transmission. Actuator and valve are directly connected by a nut.

An integrated mechanism limits the stem force. Installed microswitches switch off the actuator precisely when the specified stem force is reached.

The close-off position is self-adjusting by means of an automatic synchronization function. Synchronization is performed when the applied control signal is 0 V or 10 V. The actuator then checks its end position every 20 minutes. Any manual operation will be detected within 20 minutes, at the latest, and the actuator will return to its end position after that control cycle.

Manual Operation for ML7430E

The actuators are equipped with a manual operator. Manual operation is possible only after the power supply has been switched off or disconnected. It should be used only to check the valve operation. To operate, turn the manual operator knob clockwise to move the stem downward and counter-clockwise to move the stem upward.

Manual Operation for ML7435E

The actuators are equipped with a manual operator (for 8 mm Hex Key). Manual operation is possible only after the power supply has been switched off or disconnected. It disables the actuators safety function and should be used only to check the valve operation. The manual operator is located under the cover.

Electrical Installation

To avoid the voltage drop influence of the cabling, it is recommended that you wire control signal Y and 24 V_L separately from power supply wiring.

Input Signal Range

The range of the analog input signal Y (0...10 Vdc or 2...10 Vdc) can be selected by changing the position of jumper plug W2 (see Fig. 1). The factory set is at 0...10 Vdc.

Direction of Action

The direction of action (direct or reverse) can be selected by changing the position of jumper plug W1 (see Fig. 1). It is set by the factory such that the stem extends at increasing signal and retracts at decreasing signal (direct action).

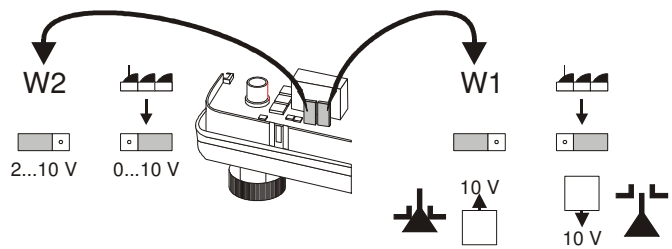

Fig. 1. Jumper plugs W1 and W2

NOTE: Jumper plugs W1 and W2 are accessible after the cover has been removed (see Fig. 1).

Y-Signal Override

To override the Y-signal and force the actuator in 0% or 100% stroke position, inputs 1 and 2 (see Fig. 4 and Fig. 5) must be connected as follows:

- 0% stroke position (stem fully retracted):
24 V \perp applied to input Y
- 100% stroke position (stem fully extended):
24 V \sim applied to input Y
- or vice versa if reverse action is selected

Y-Signal break

In the event of a wire break at the Y-signal input, the actuator is moved into the 0 V signal position (safety position).

Spring Return (ML7435E1004, only)

The ML7435E1004 spring return actuator provides a defined safety position of the valve in case of power failure.

In the event of a power failure, the actuator retracts its stem.

Suitable Valves

	DN15	DN20	DN25	DN32	DN40	order no.
close-off pressure in kPa	1600	--	1600	--	--	V5872B
	-	--	1600	1200	1000	V5832B
	-	--	1600	1200	1000	V5833A
	2500	2500	2500	2500	--	V5825B

Approvals

NOTE: Actuator ML7435E1004 in combination with the following valves is approved according to DIN EN 14597:

valve OS-no.	DIN registration no.
V5825B	1F152/08

DIMENSIONS

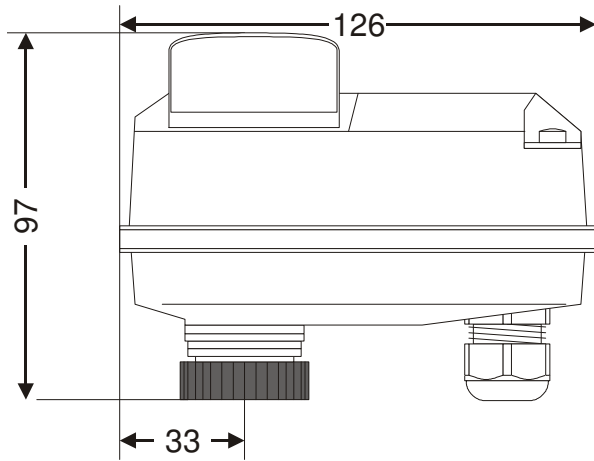

Fig. 2. ML7430E (dimensions in mm)

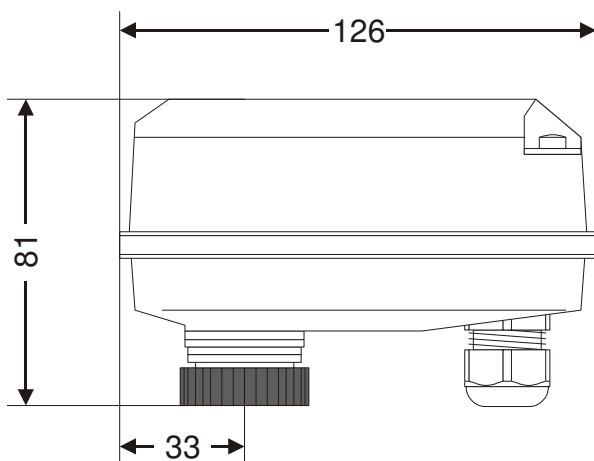
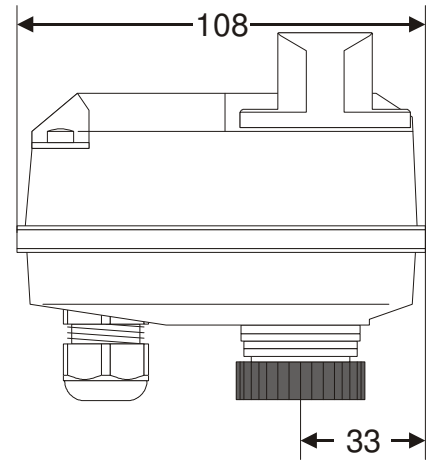
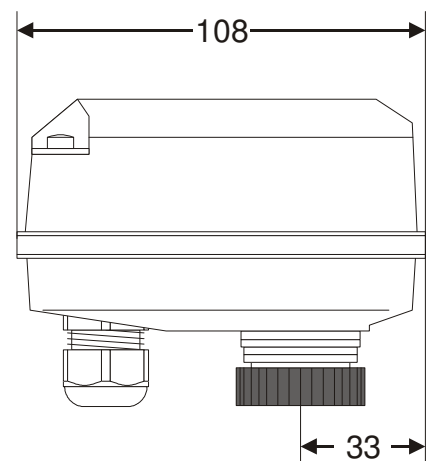

Fig. 3. ML7435E (dimensions in mm)



WIRING

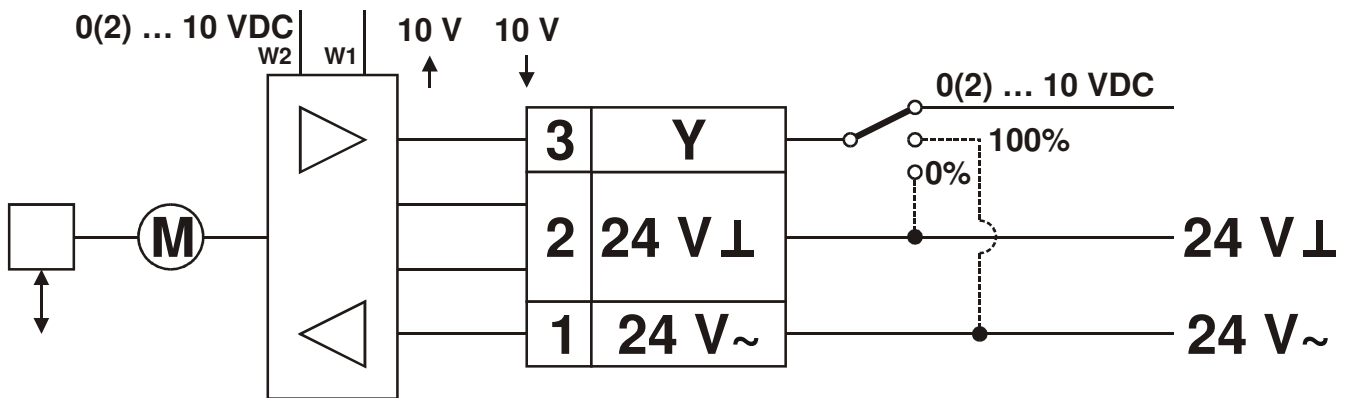

Fig. 4. ML7430E, wiring

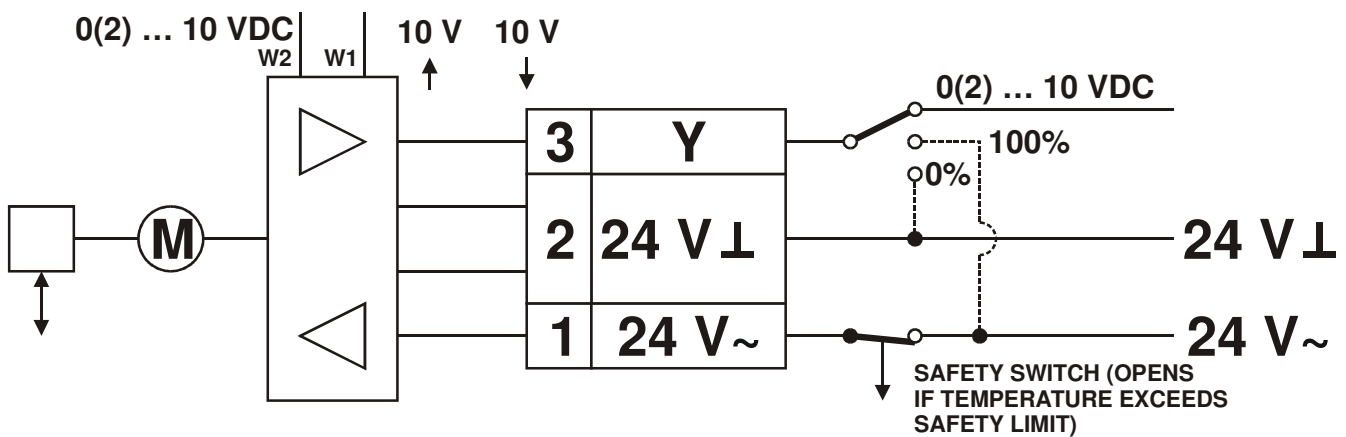

Fig. 5. ML7435E, wiring

Honeywell

Manufactured for and on behalf of the Environmental and Combustion Controls Division of Honeywell Technologies Sàrl, Rolle, Z.A. La Pièce 16, Switzerland by its Authorized Representative:

Automation and Control Solutions

Honeywell GmbH
Böblinger Strasse 17
71101 Schönaich
Germany

Phone: (49) 7031 63701

Fax: (49) 7031 637493

<http://ecc.emea.honeywell.com>

Subject to change without notice. Printed in Germany

EN0B-0260GE51 R0611